

SFB280920

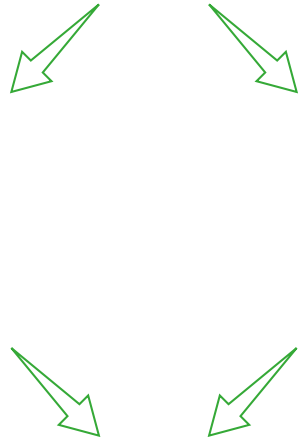

Start



Components

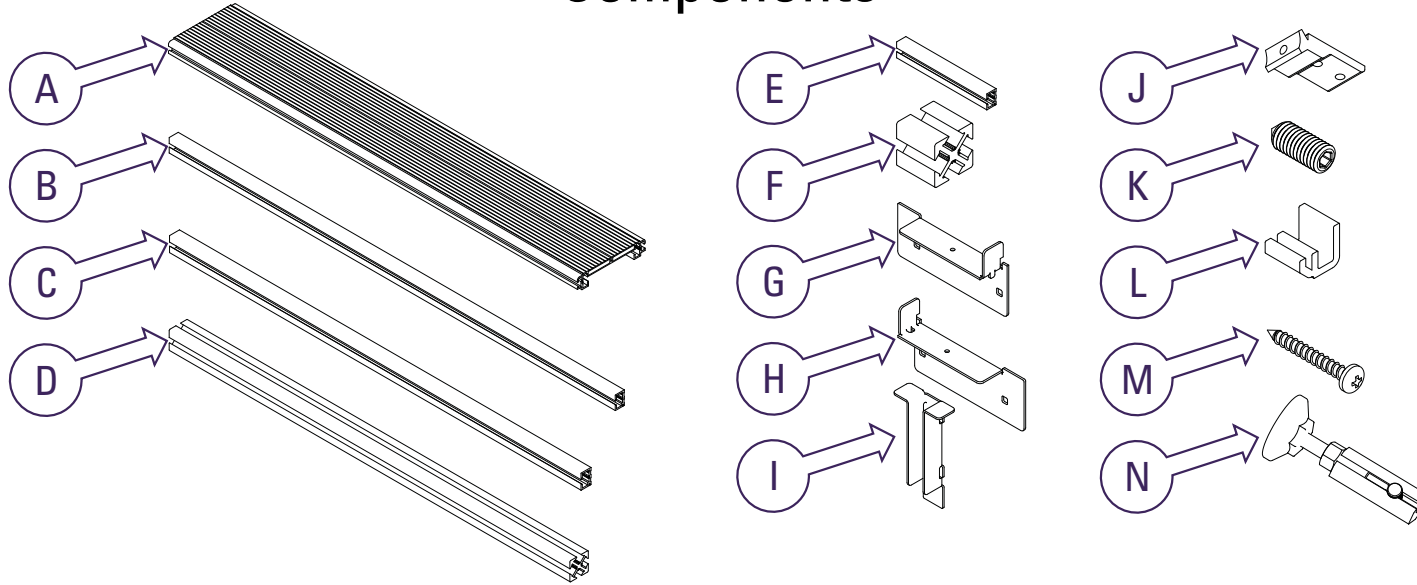

Part Description		Part quantities based on bench model								
		SFB110 Quantity	SFB160 Quantity	SFB210 Quantity	SFB260 Quantity	SFB310 Quantity	SFB360 Quantity	SFB410 Quantity	SFB460 Quantity	SFB510 Quantity
A	Bench edge	1 x 1320mm / 52"	2 x 890mm / 35 1/16"	2 x 1140mm / 44 7/8"	2 x 1390mm / 54 3/4"	3 x 1080mm / 42 1/2"	3 x 1247mm / 49 1/16"	3 x 1413mm / 55 5/8"	4 x 1175mm / 46 1/4"	4 x 1300mm / 5 3/16"
B	Beam1	3 x 1320mm / 52"	6 x 890mm / 35 1/16"	6 x 1140mm / 44 7/8"	6 x 1390mm / 54 3/4"	9 x 1080mm / 42 1/2"	9 x 1247mm / 49 1/16"	9 x 1413mm / 55 5/8"	12 x 1175mm / 46 1/4"	12 x 1300mm / 5 3/16"
C	Beam2 (1247mm / 49 1/16")	4	6	6	6	8	8	8	10	10
D	Leg	4	6	6	6	8	8	8	10	10
E	Cantilever arm	2	3	3	3	4	4	4	5	5
F	Cantilever joiner	2	3	3	3	4	4	4	5	5
G	Left support plate	1	1	1	1	1	1	1	1	1
H	Right support plate	1	1	1	1	1	1	1	1	1
I	Intermediate support plate	0	1	1	1	2	2	2	3	3
J	Corner bracket	20	34	34	34	48	48	48	62	62
K	Grub screw	60	102	102	102	144	144	144	186	186
L	Worktop fixing bracket	6	11	11	11	16	16	16	21	21
M	Worktop fixing screw	6	11	11	11	16	16	16	21	21
N	Adjustable foot	4	6	6	6	8	8	8	10	10

Tools included

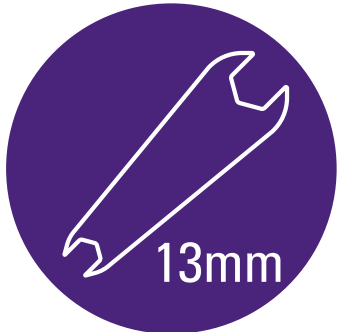
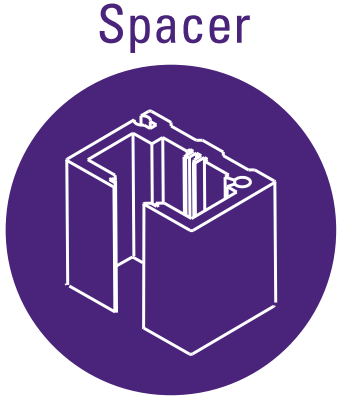

Tools not included



Be careful with lifting



To prevent injury and damage, lift the boxes with 2 people.

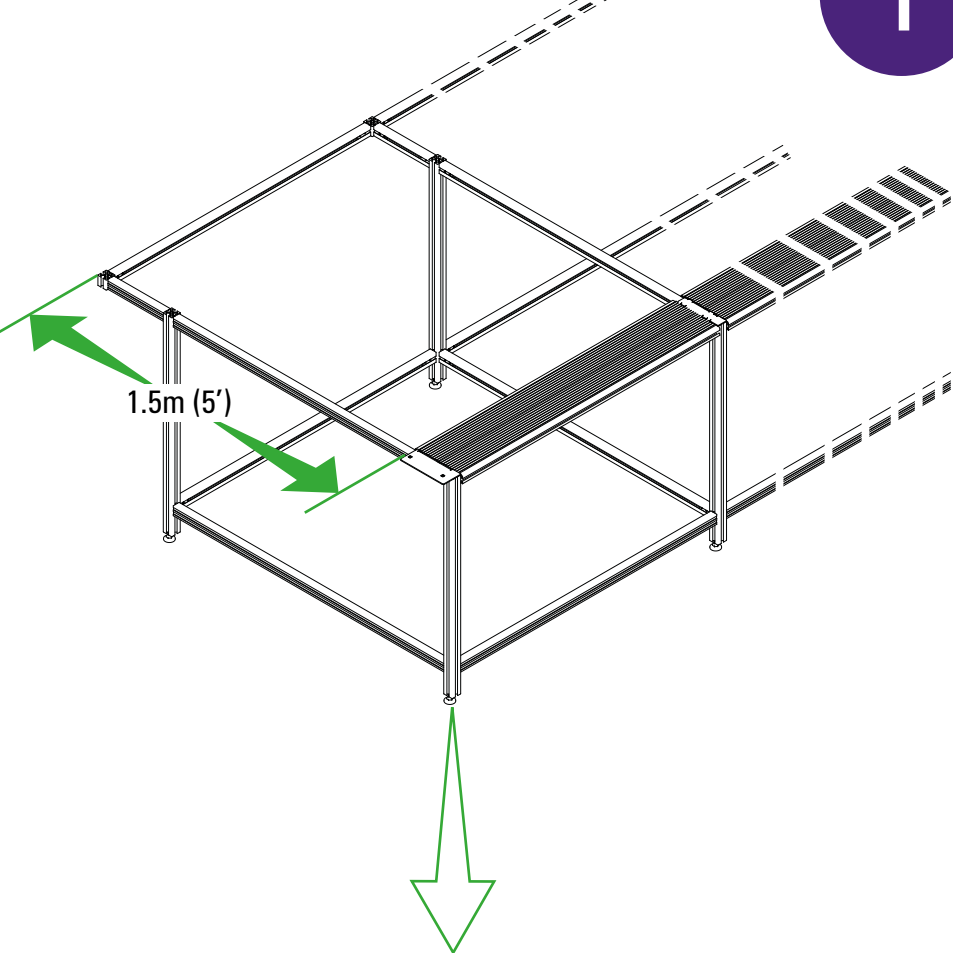
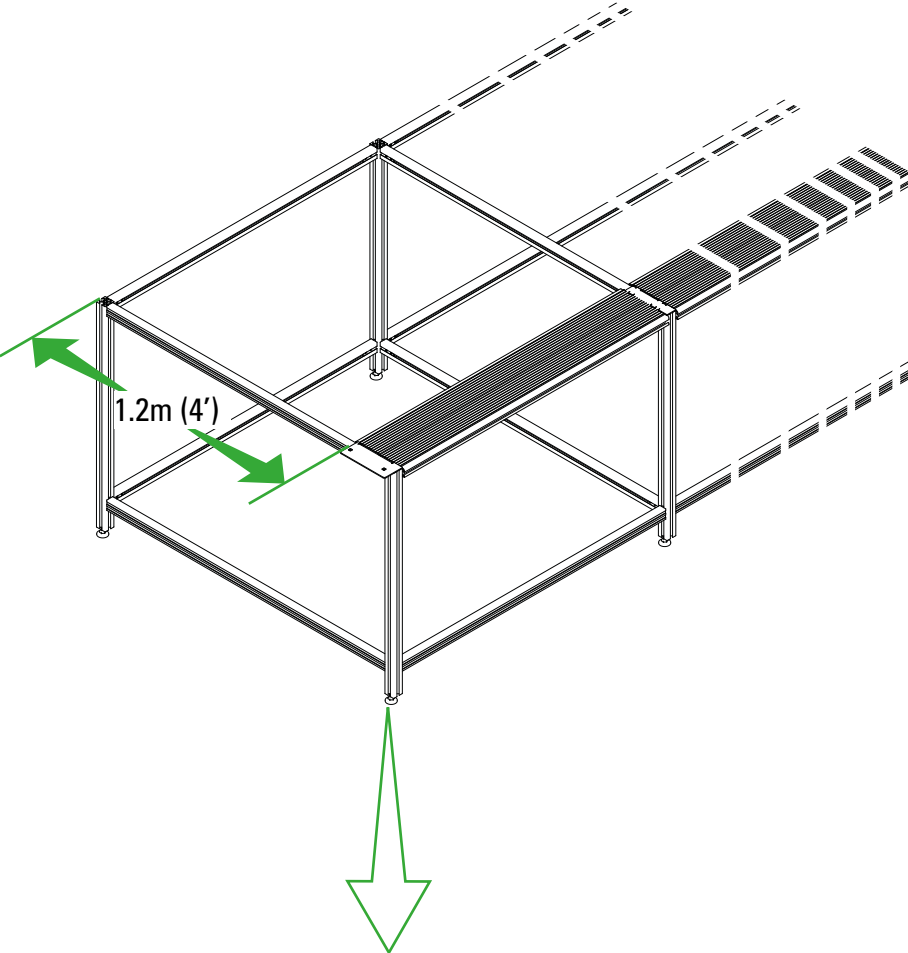

Without cantilever



Prepare the brackets

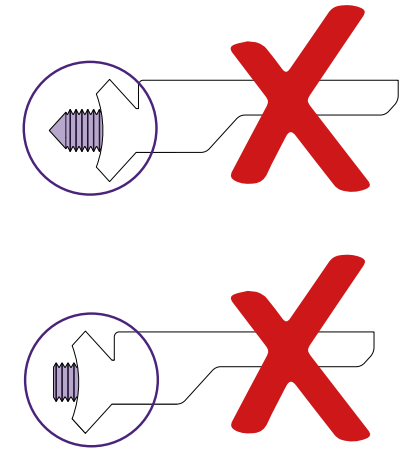
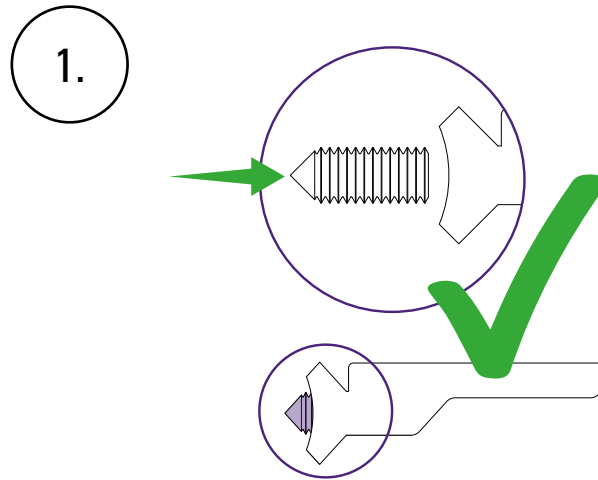
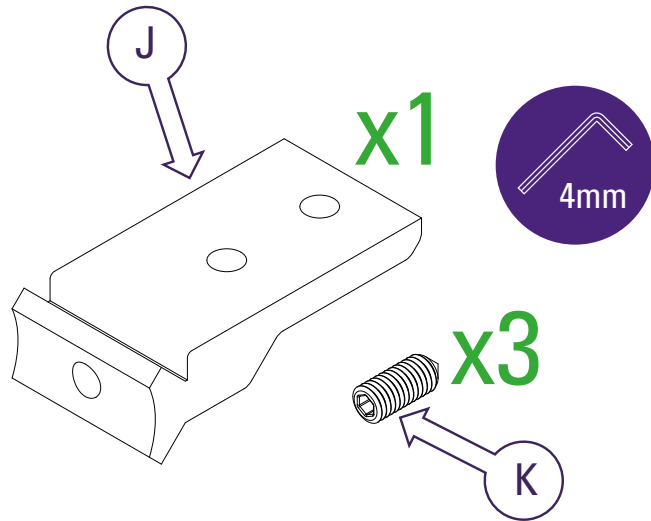

1. Insert a grub screw backwards into the bracket and screw into place until only 2 threads are showing.
2. Insert two grub screws in from the flat face of the bracket 2 turns only.

IMPORTANT: Make the brackets for your bench using all J and K parts supplied.

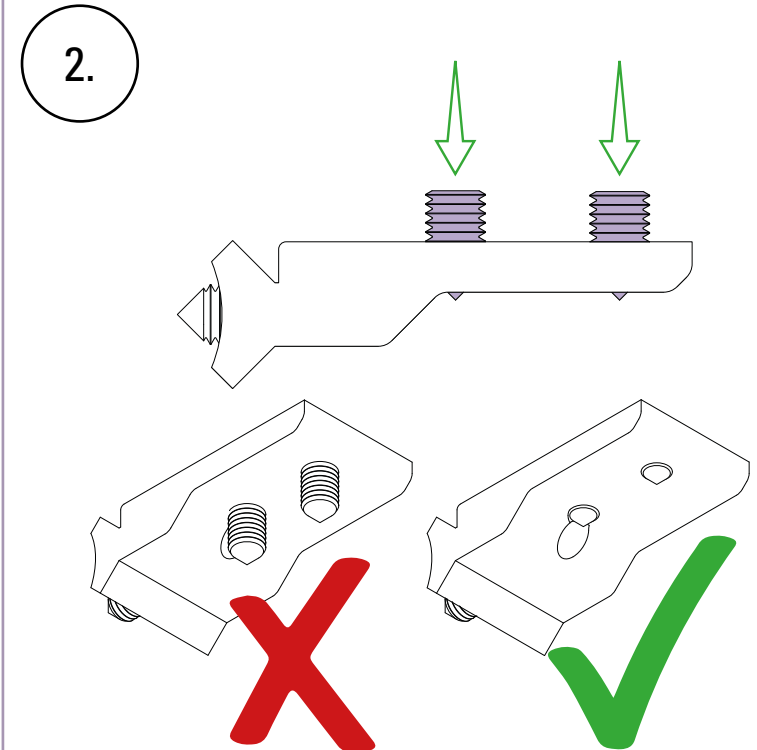

How to fit the brackets

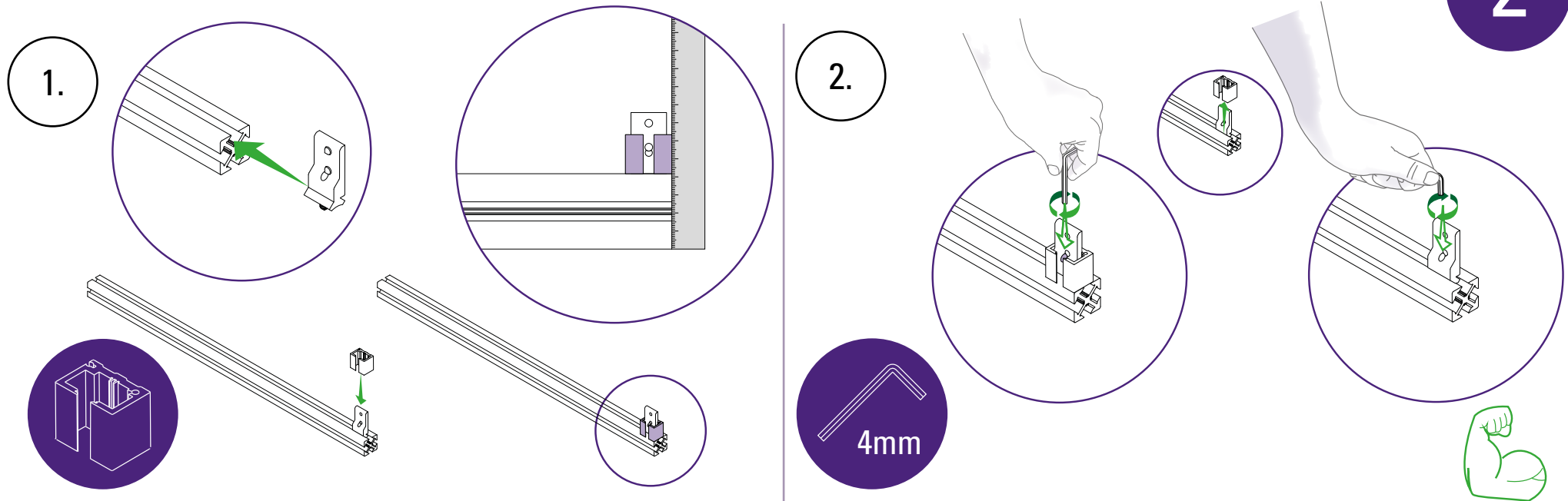

1. Slide a corner bracket into position and place the spacer over it. Hold the spacer so it is flush with the top of the leg. Use a straight edge to ensure that the spacer is flush with the end of the leg.
2. Initially tighten gently with the long end of the Allen key. Then remove the spacer and fully tighten with a further 2-3 half turns using the short end of the Allen key.

IMPORTANT: These steps are essential to ensure the finished bench is rigid. The spacers must be aligned precisely, and be flush with the ends of the leg. The screws must be tightened fully.

Build the legs

Add the brackets (page 9) to the leg (part D)

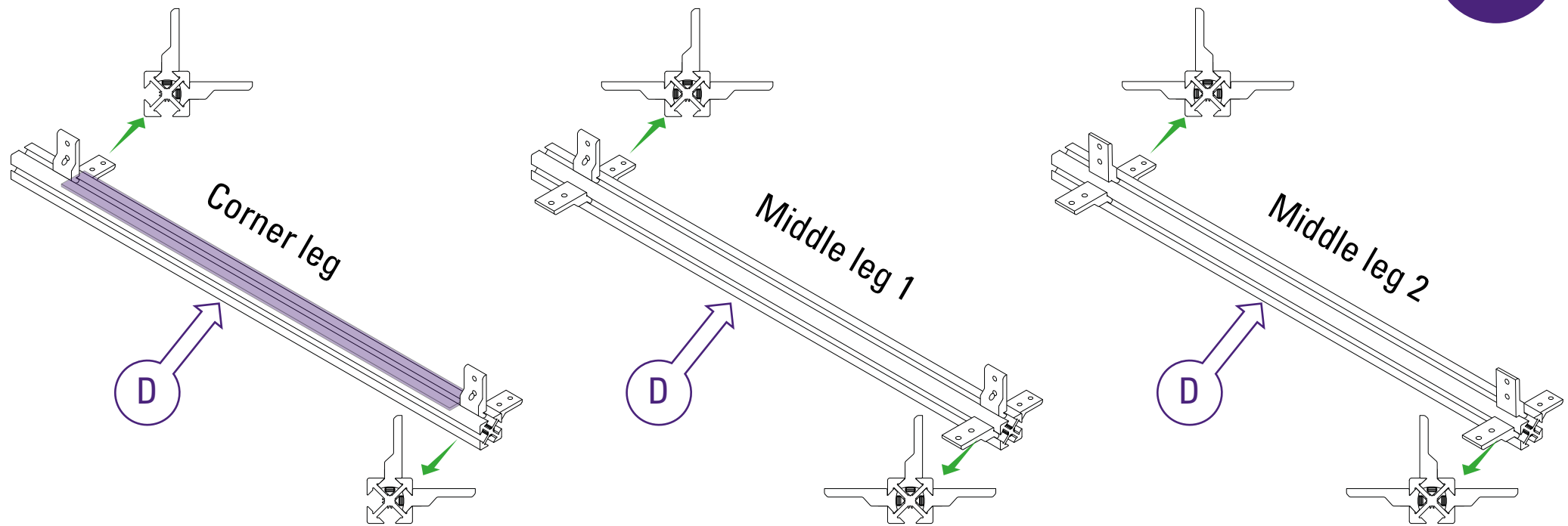

Unit Type	Corner Leg	Middle Leg 1	Middle Leg 2
SFB110	4	0	0
SFB160 / SFB210 / SFB260	4	1	1
SFB310 / SFB360 / SFB410	4	2	2
SFB460 / SFB510	4	3	3

The lower brackets can be fixed at any point along the leg as long as they are all the same distance from the upper brackets. Use a tape measure or make a spacer from an off-cut of board as shown in purple on the corner leg arrangement.

IMPORTANT: The brackets must be inserted into the legs in the orientation specified. If the orientation of the brackets does not match the image above, the bench will not assemble properly.

Attach the feet

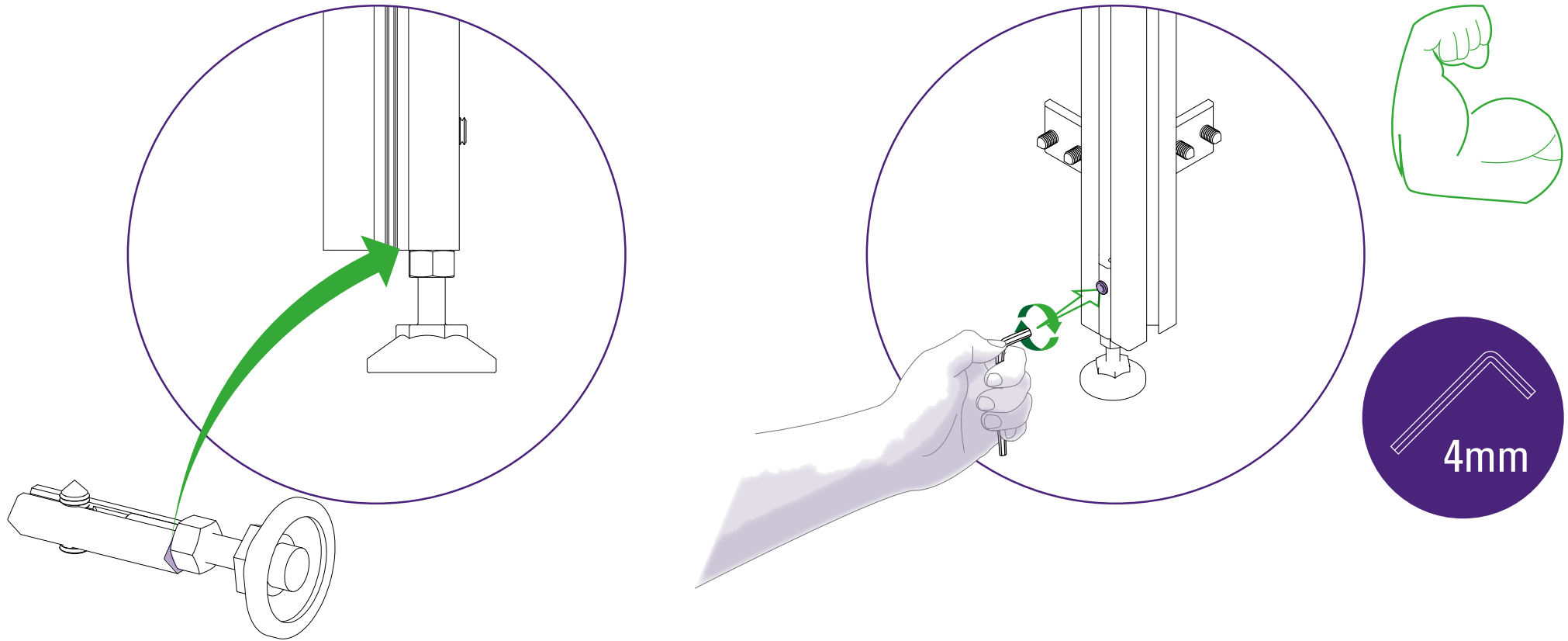

Fix an adjustable foot into any of the four grooves at the bottom of each leg, make sure the aluminium block is flush with the bottom of the leg. Fix the screw very tightly.

Glass worktop installation preparation

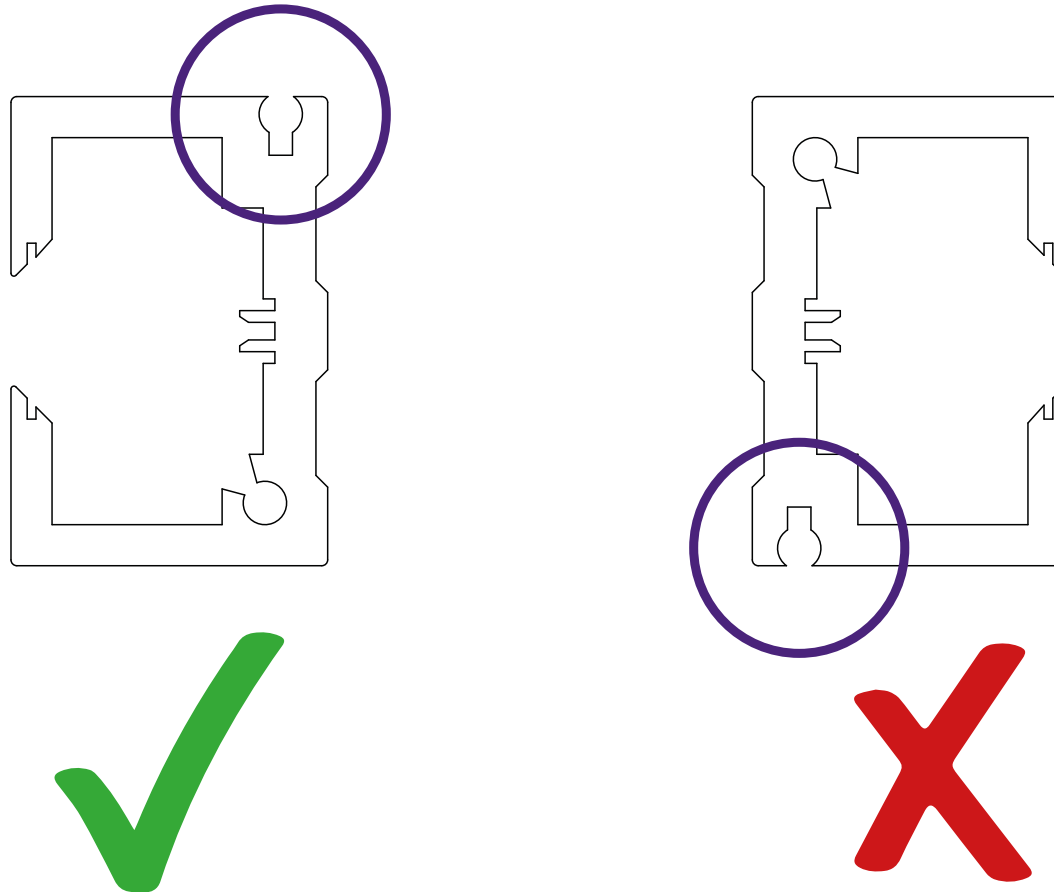

IMPORTANT: If you are using a glass worktop on your bench, the highlighted detail on the beam extrusion (part C - page 4) must be facing upwards (towards the work surface) as it will hold a white silicone chord that will be in contact with the glass. Details can be seen on page 49.

Note: White silicone chord required for installing a glass work top is sold separately. Please visit our website or contact your dealer for more details.

Build the leg frames

(See page 14-16 for detailed instructions)

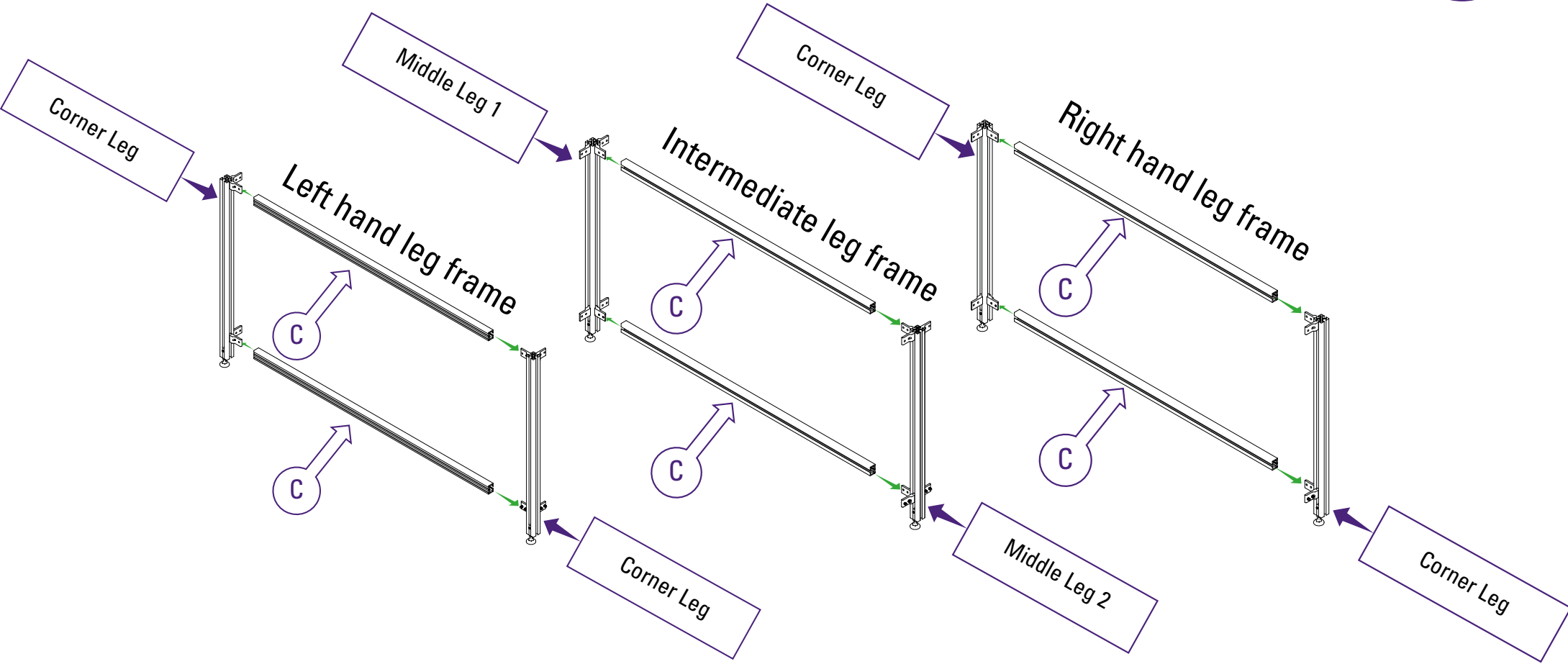

Unit	Number of left hand leg frames	Number of intermediate leg frames	Number of right hand leg frames
SFB110	1	0	1
SFB160 / SFB210 / SFB260	1	1	1
SFB310 / SFB360 / SFB410	1	2	1
SFB460 / SFB510	1	3	1

How to build a left hand leg frame

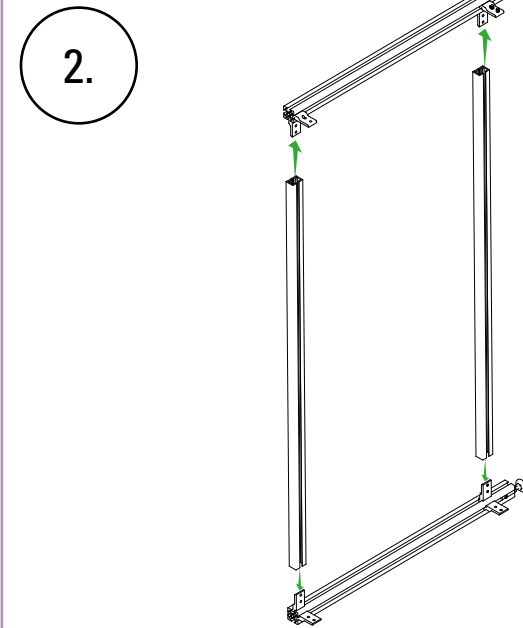
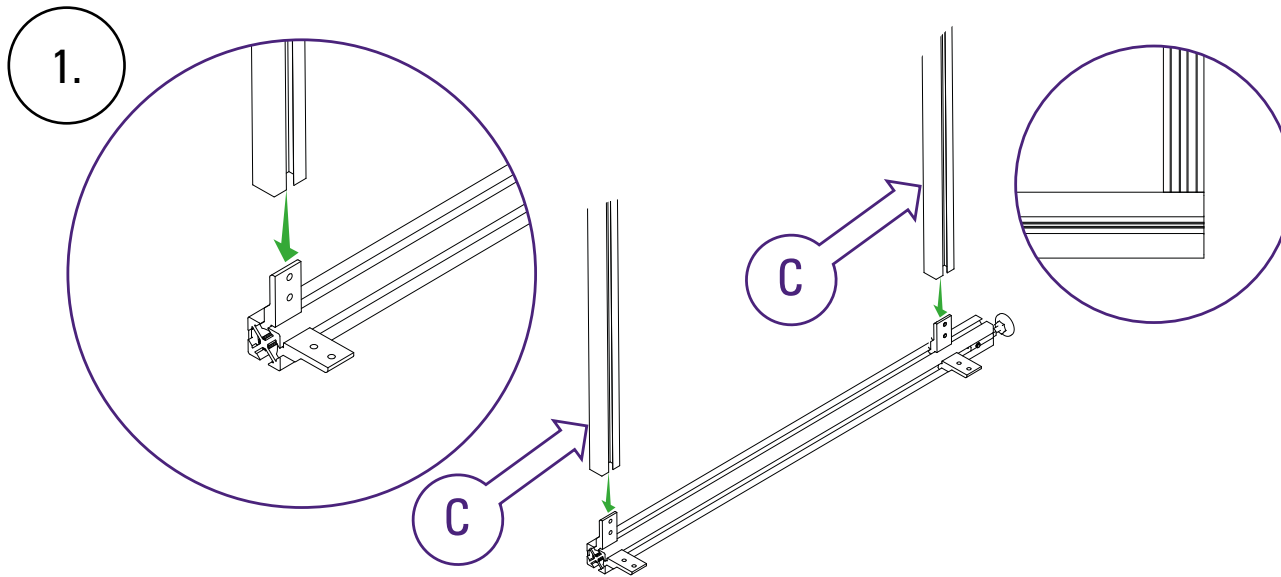

1. Take a pair of corner legs (page 11) and lay one on the floor. Place a beam2 (part C - page 4) on each bracket. Do not tighten the screws yet.
2. Place the second corner leg over the other end of the beams. Press down and ensure all the beam ends are flush against the leg
3. Tighten the screws using the 4mm Allen key supplied. There are lots of screws, so you can save time by using a battery operated screwdriver. Whichever method you use, fasten the screws firmly with the Allen key.

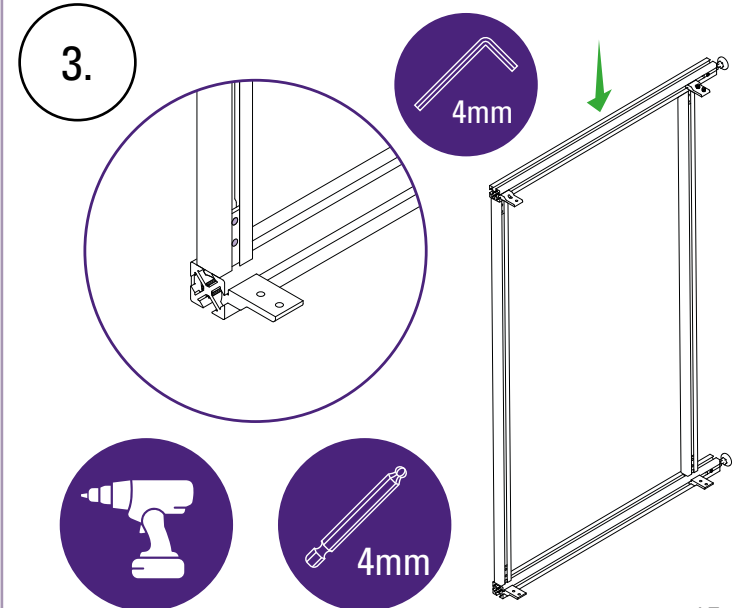

How to build an intermediate hand leg frame

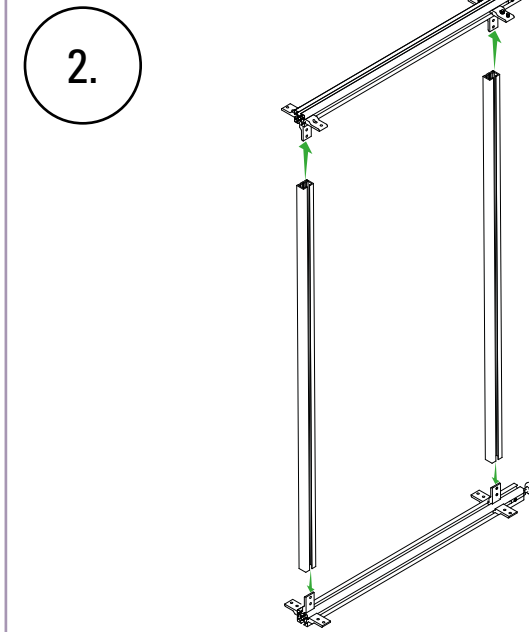
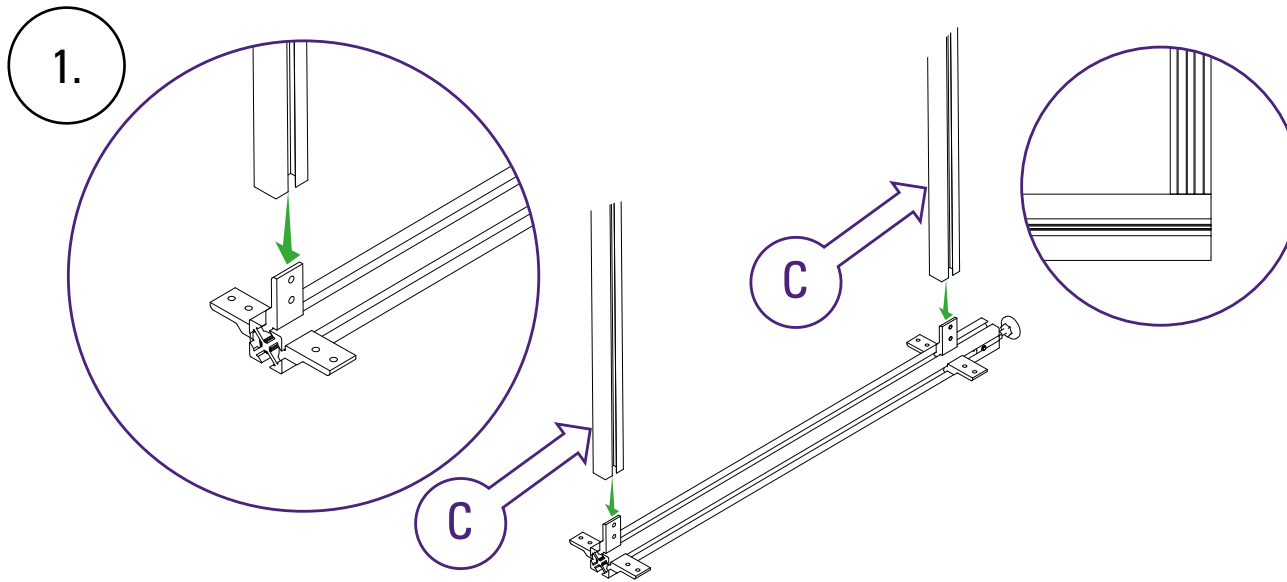

1. Take a middle leg 1 (page 11) and lay one on the floor. Place a beam 2 (part C - page 4) on each bracket. Do not tighten the screws yet.
2. Place middle leg 2 over the other end of the beams. Press down and ensure all the beam ends are flush against the leg.
3. Tighten the screws using the 4mm Allen key supplied. There are lots of screws, so you can save time by using a battery operated screwdriver. Whichever method you use, fasten the screws firmly with the Allen key.

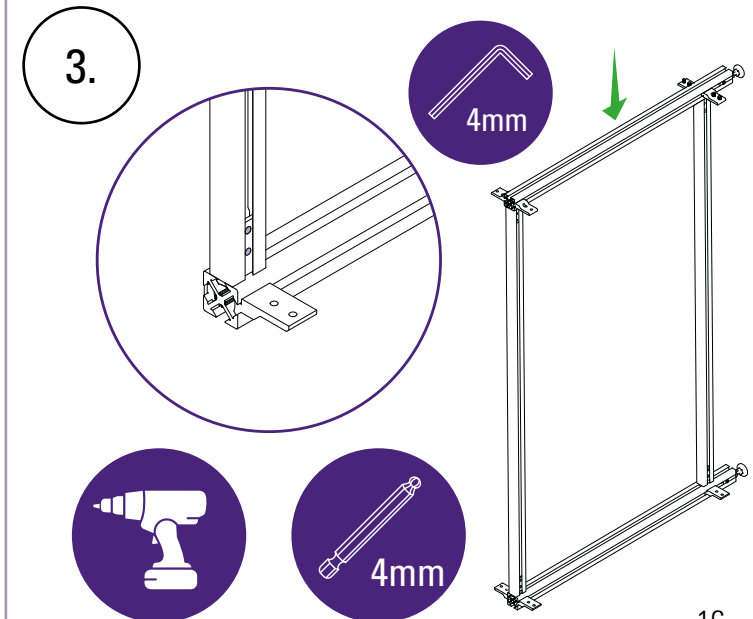

How to build a right hand leg frame

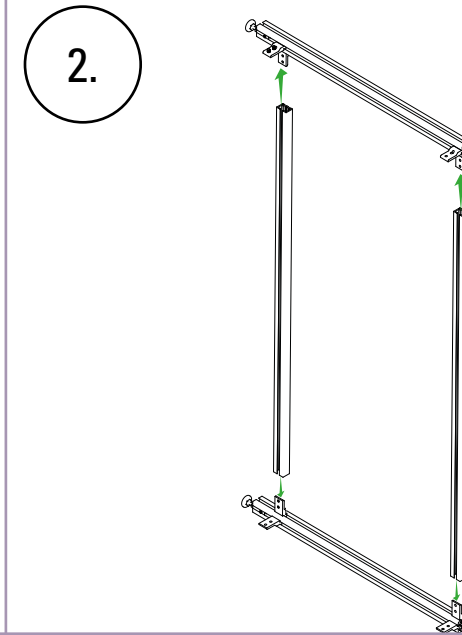
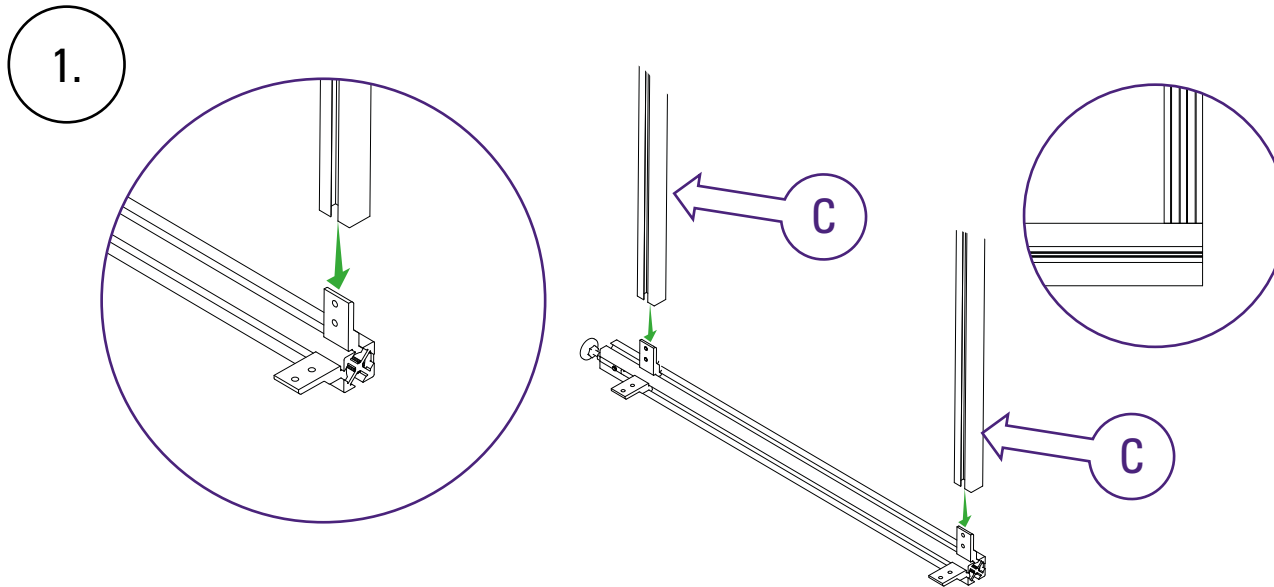

1. Take a pair of corner legs (page 11) and lay one on the floor. Place a beam2 (part C - page 4) on each bracket. Do not tighten the screws yet.
2. Place the second corner leg over the other end of the beams. Press down and ensure all the beam ends are flush against the leg
3. Tighten the screws using the 4mm Allen key supplied. There are lots of screws, so you can save time by using a battery operated screwdriver. Whichever method you use, fasten the screws firmly with the Allen key.

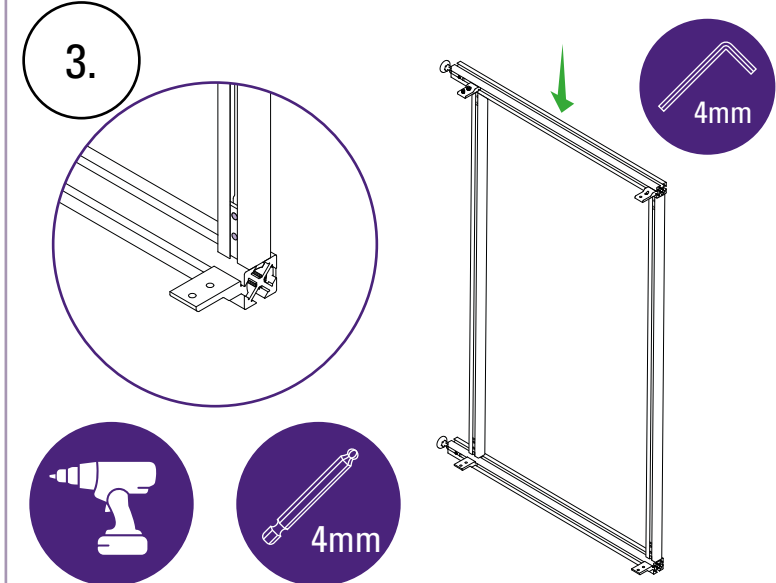

Assemble the bench upside down (1/4)

1.

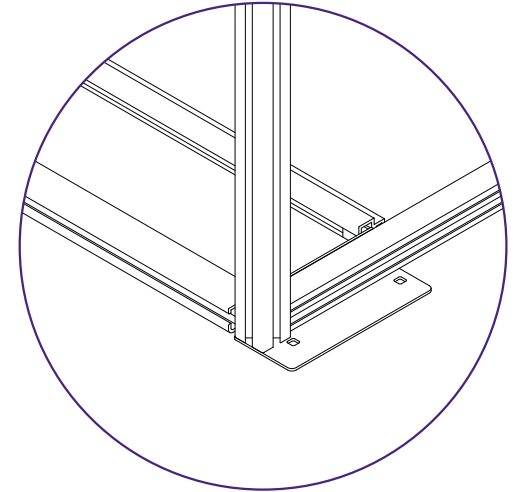
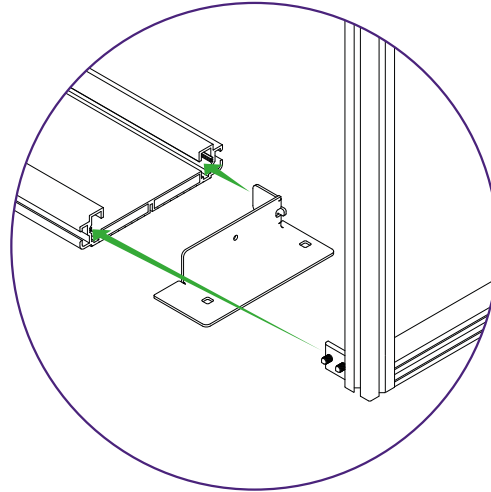
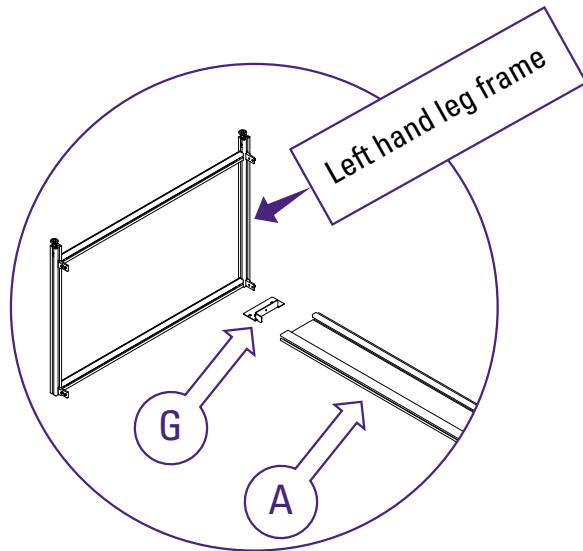

The bench is assembled up side down then turned over when complete

1.

Place a bench edge (part A - page 4), flat side down, on the floor together with the left support plate (Part G) and left hand leg frame. Slide the parts together.

2.

Place three beams on the remaining brackets.

2.

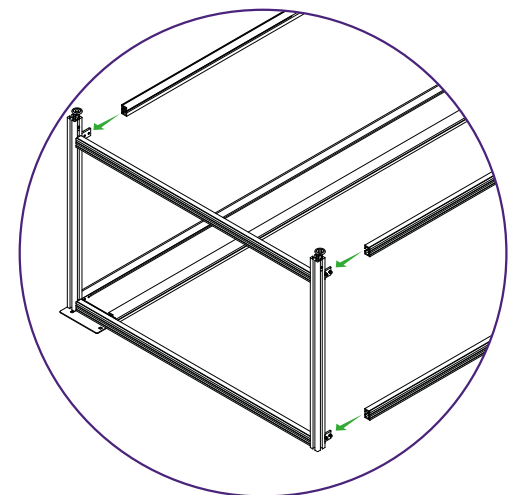

IMPORTANT: Do not tighten any screws at this stage. Details for tightening screws on page 20.

Assemble the bench upside down (2/4)

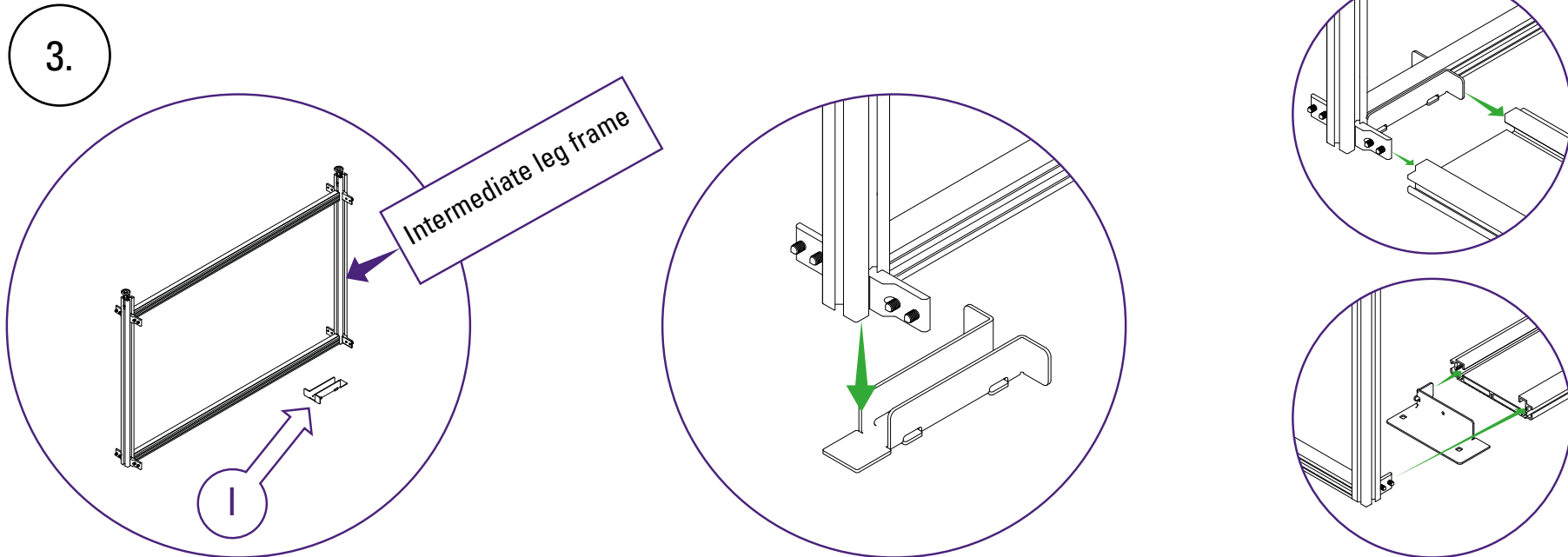

IMPORTANT: If constructing a SFB110, substitute intermediate leg frame for right hand leg frame.

3. Place an intermediate leg frame onto an intermediate support plate (Part I) and slide so the bracket just enters 1cm into the bench edge (Part A).
4. Align the other three beams and push the frame into position.

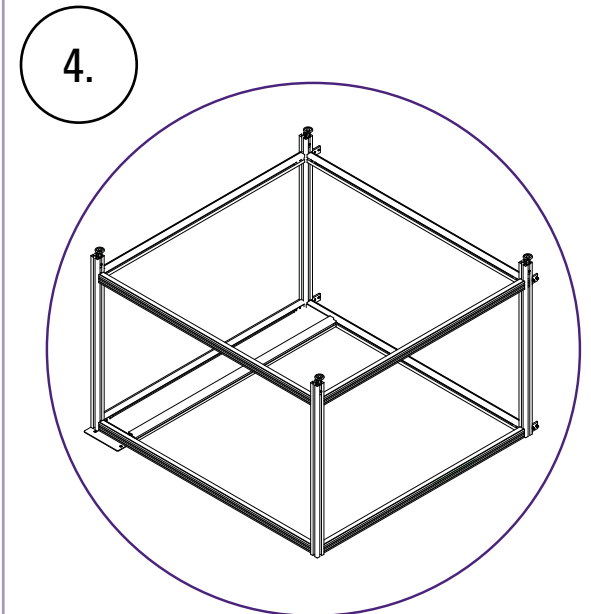

Assemble the bench upside down (3/4)

5.

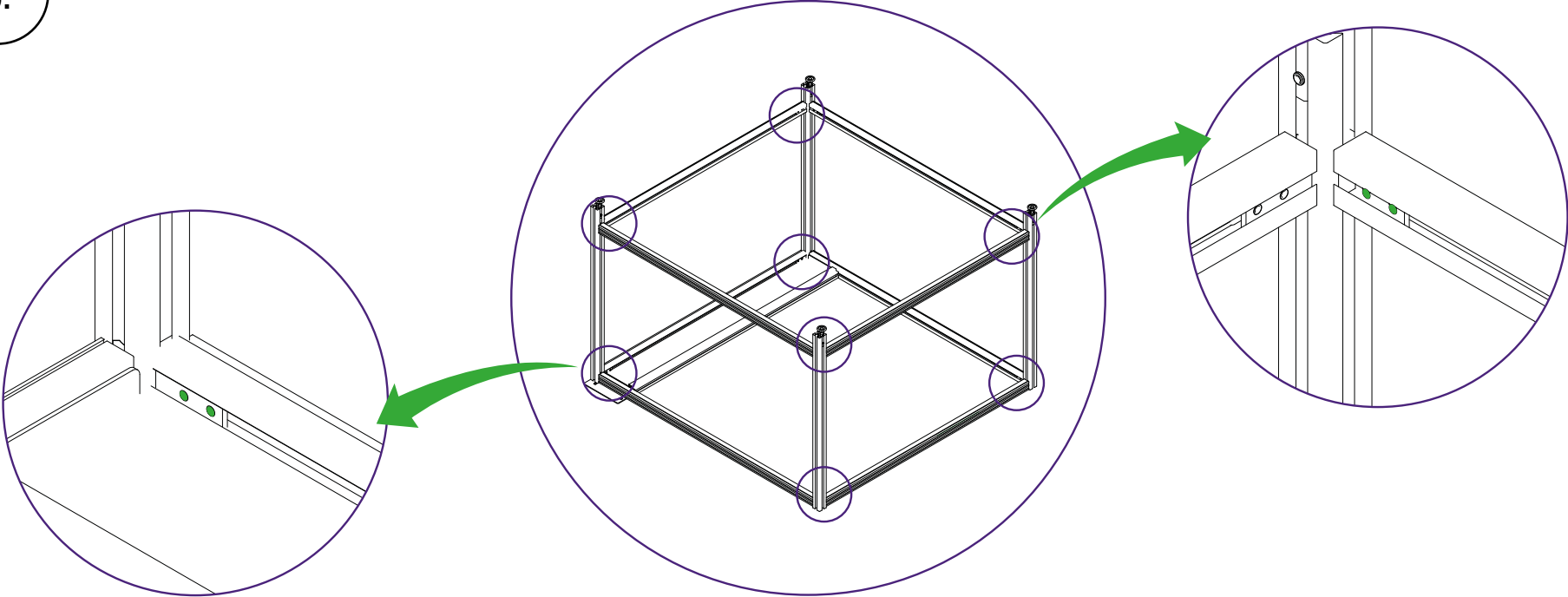

5.

Tighten the remaining loose screws in this section firmly (as shown on page 10).

6.

Continue to build your bench in this way until you reach the end.

6.

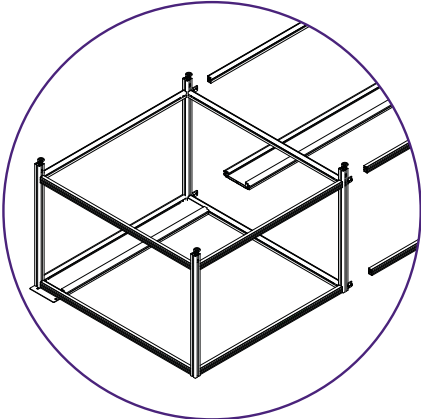

Assemble the bench upside down (4/4)

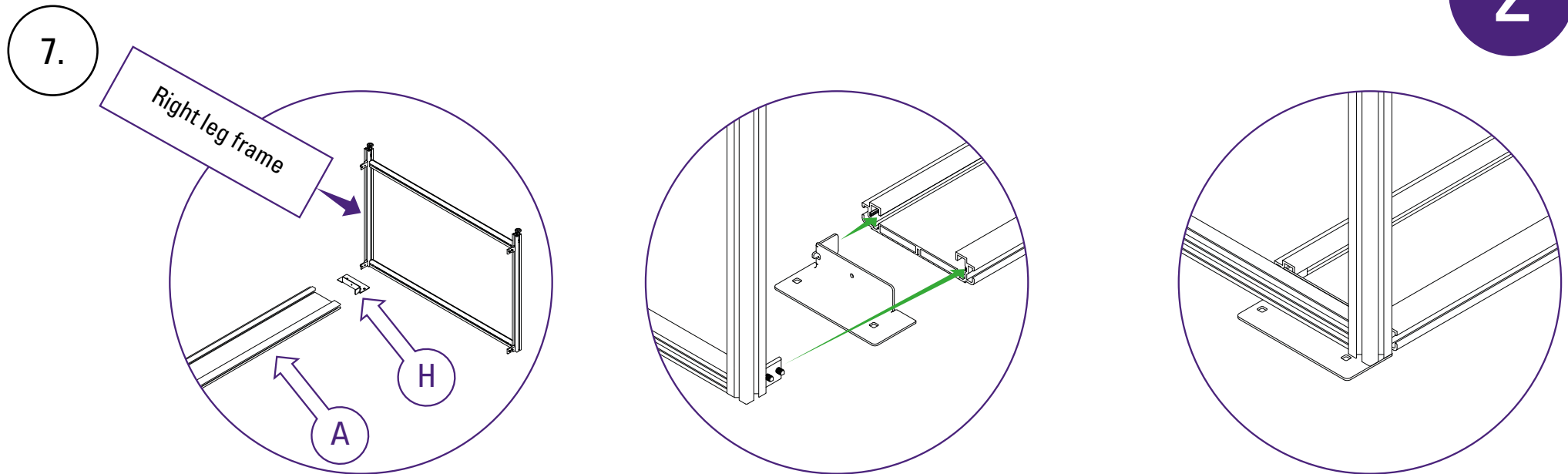

7. To complete your bench assembly, place a right hand leg frame onto an right support plate (Part H) and slide so the bracket just enters 1cm into the bench edge (Part A).

8. Align the other three beams and push the frame into position. Tighten all screws fully, checking that there are no gaps.

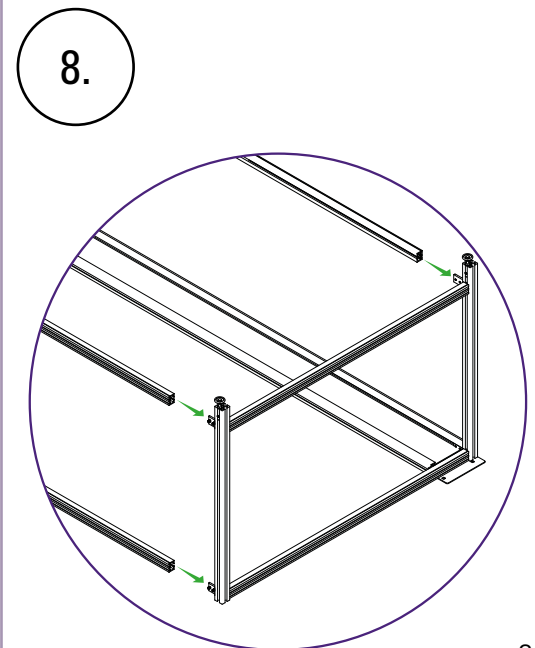

Flip the bench over once assembled

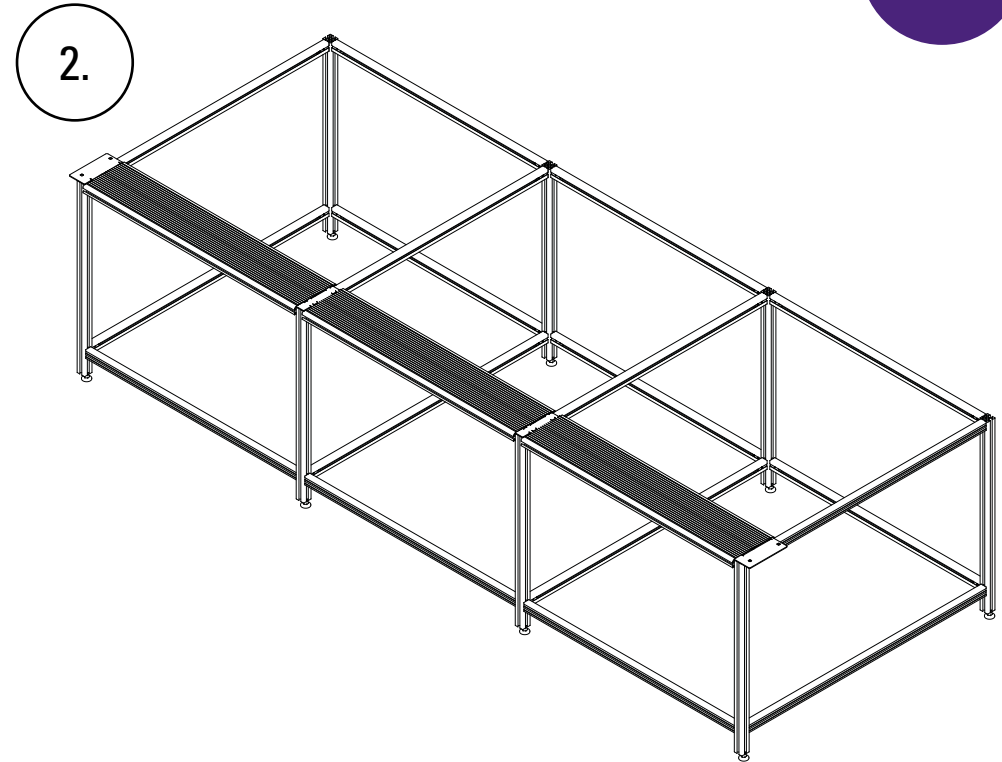
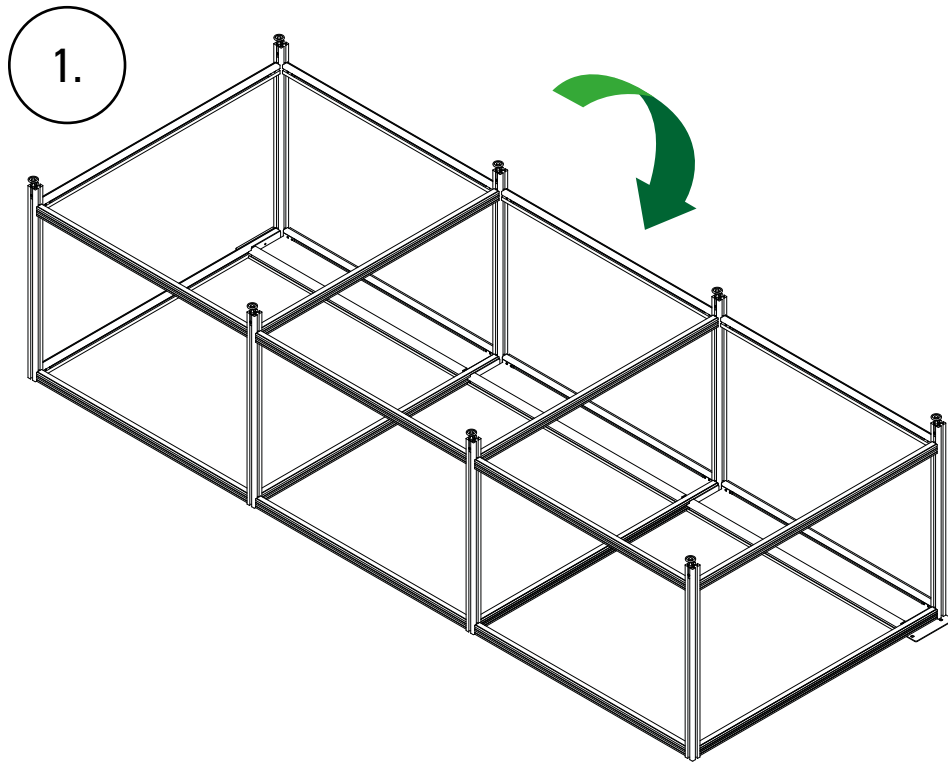

Turn the bench over by rolling onto its front face and then onto its feet. Place in its final working position

IMPORTANT: Before the cutter is mounted it is essential the bench edge extrusions are all flat to within 3mm. Using a spirit level follow the sequence in section 4.



With cantilever



Prepare the brackets

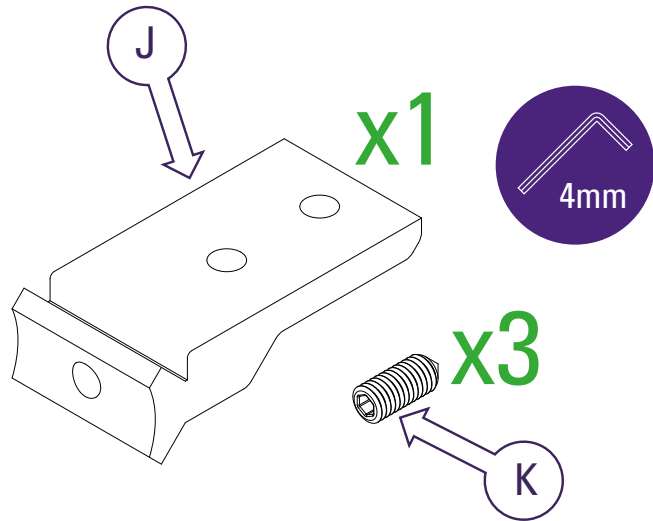

1.

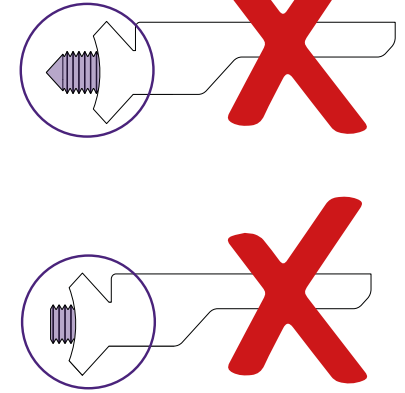
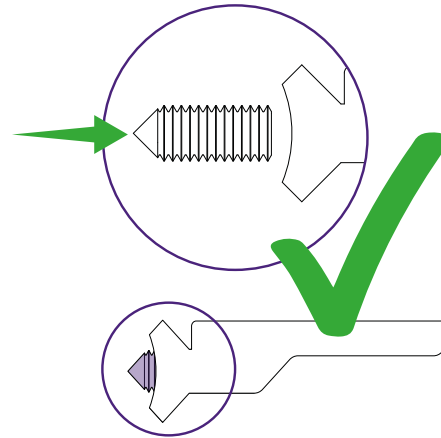

1. Insert a grub screw backwards into the bracket and screw into place until only 2 threads are showing.
2. Insert two grub screws in from the flat face of the bracket 2 turns only.

2.

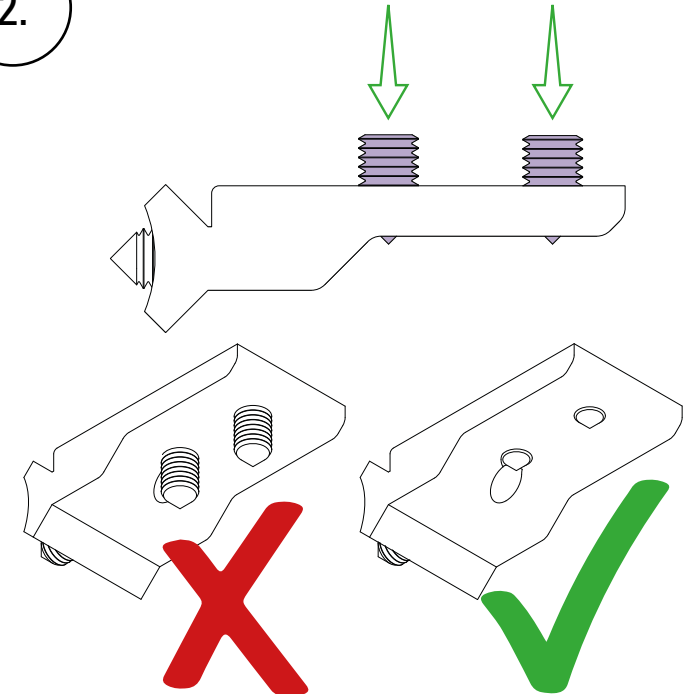

IMPORTANT: Make the brackets for your bench using all J and K parts supplied.

How to fit the brackets

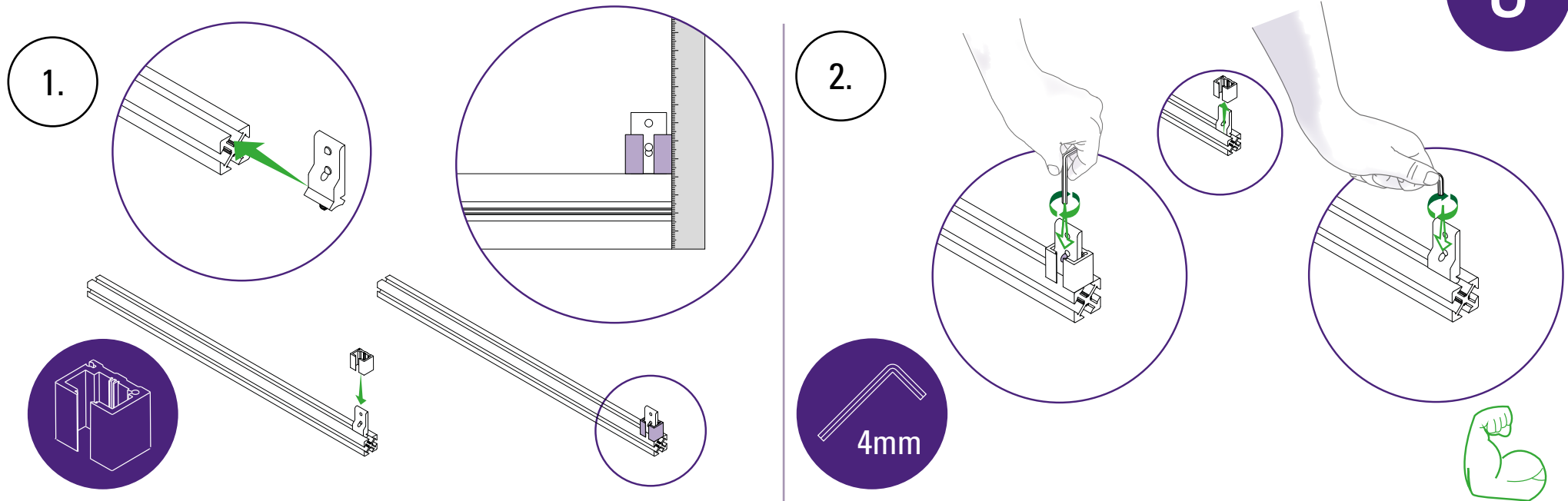

1. Slide a corner bracket into position and place the spacer over it. Hold the spacer so it is flush with the top of the leg. Use a straight edge to ensure that the spacer is flush with the end of the leg.
2. Initially tighten gently with the long end of the Allen key. Then remove the spacer and fully tighten with a further 2-3 half turns using the short end of the Allen key.

IMPORTANT: These steps are essential to ensure the finished bench is rigid. The spacers must be aligned precisely, and be flush with the ends of the leg. The screws must be tightened fully.

Attach the feet

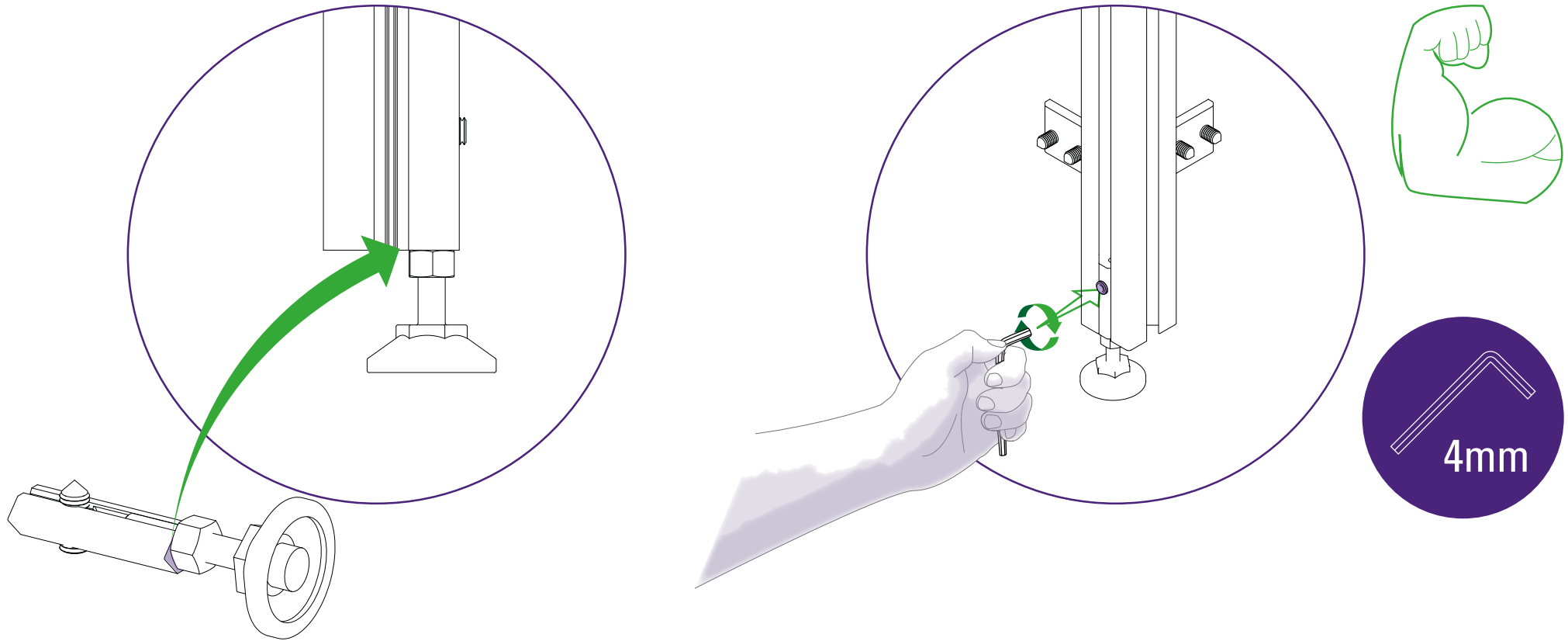

Fix an adjustable foot into any of the four grooves at the bottom of each leg, make sure the aluminium block is flush with the bottom of the leg. Fix the screw very tightly.

Build the legs

Add the brackets (page 23) to the leg (part D)

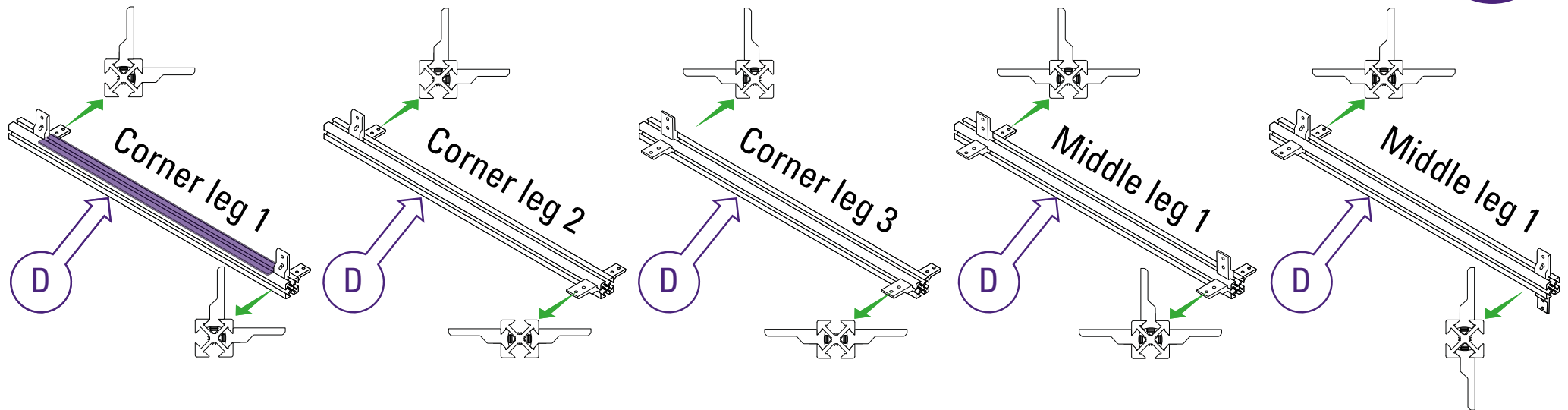

Unit Type	Corner leg 1	Corner leg 2	Corner leg 3	Middle leg 1	Middle leg 2
SFB110	2	1	1	0	0
SFB160 / SFB210 / SFB260	2	1	1	1	1
SFB310 / SFB360 / SFB410	2	1	1	2	2
SFB460 / SFB510	2	1	1	3	3

The lower brackets can be fixed at any point along the leg as long as they are all the same distance from the upper brackets. Use a tape measure or make a spacer from an off-cut of board as shown in purple on corner leg 1.

IMPORTANT: The brackets must be inserted into the legs in the orientation specified. If the orientation of the brackets does not match the image above, the bench will not assemble properly.

Prepare the leg frames

(See page 28-34 for detailed instructions)

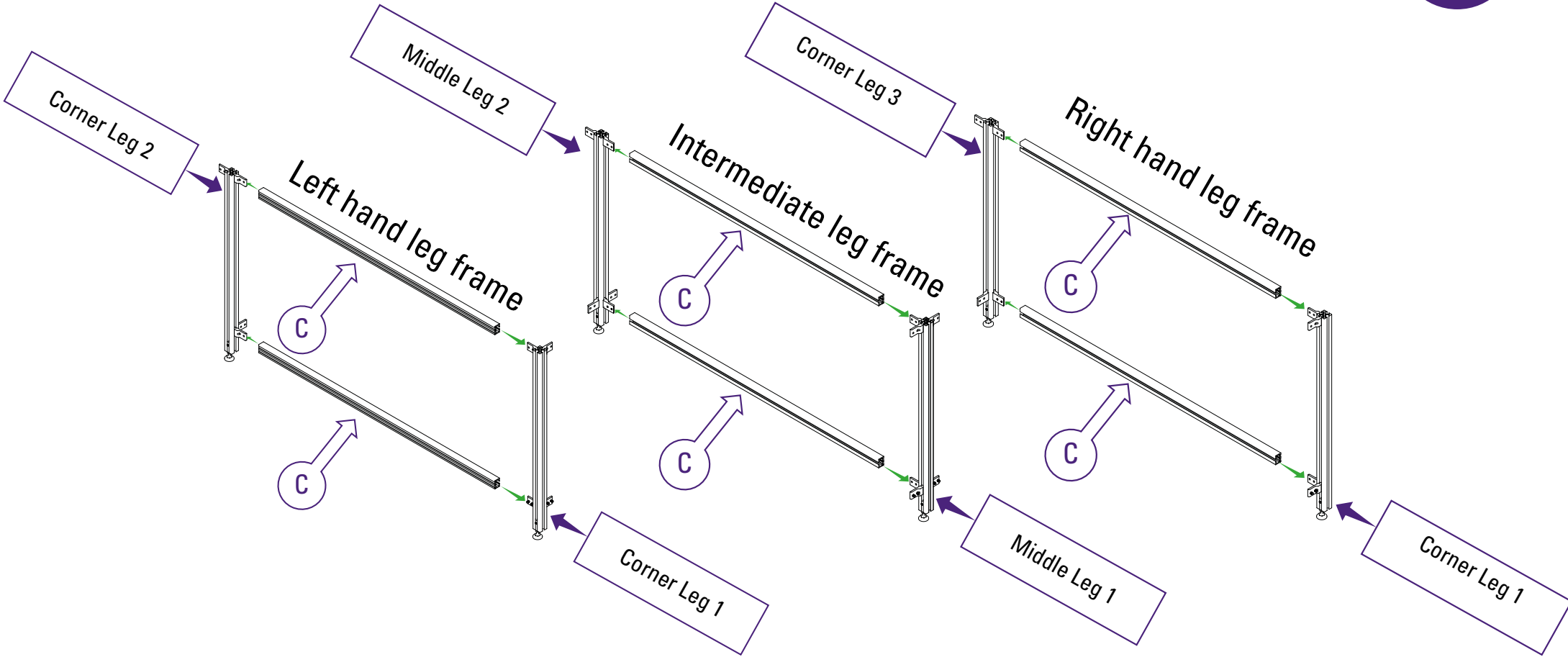

Unit Type	Number of left hand leg frames	Number of intermediate leg frames	Number of right hand leg frames
SFB110	1	0	1
SFB160 / SFB210 / SFB260	1	1	1
SFB310 / SFB360 / SFB410	1	2	1
SFB460 / SF510	1	3	1

How to build a left hand leg frame

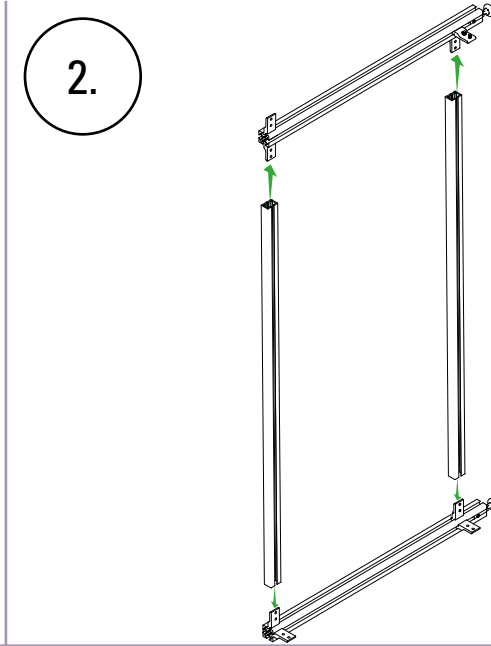
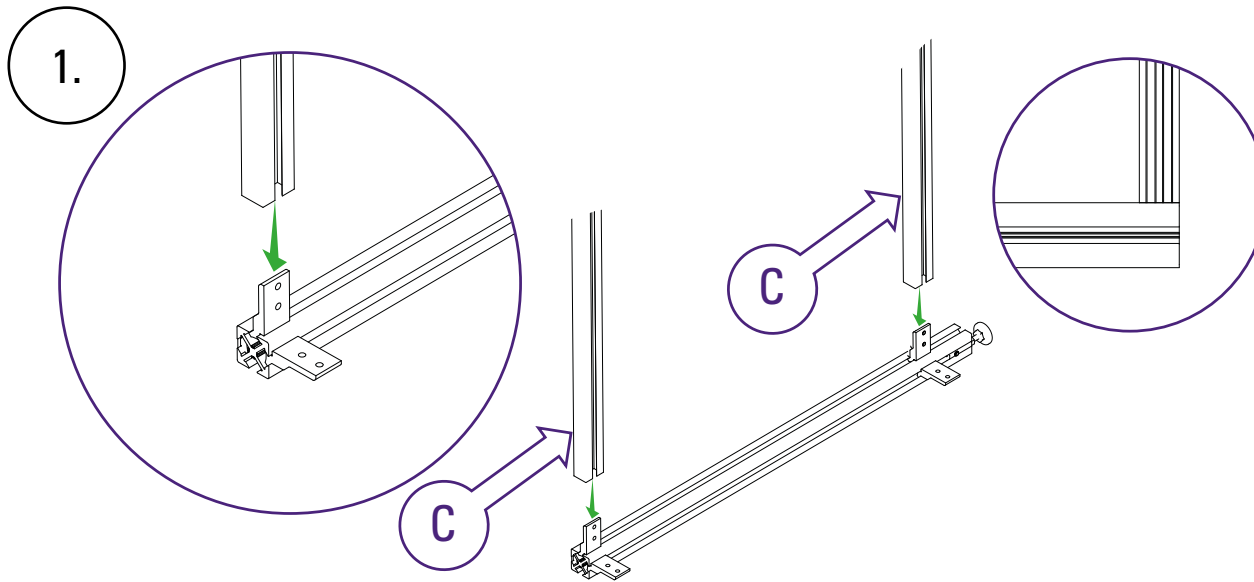

1. Take corner leg 1 (page 27) and lay one on the floor. Place a beam 2 (part C - page 4) on each bracket. Do not tighten the screws yet.

2. Place corner leg 2 over the other end of the beams. Press down and ensure all the beam ends are flush against the leg.

3. Tighten the screws using the 4mm Allen key supplied. There are lots of screws, so you can save time by using a battery operated screwdriver. Whichever method you use, fasten the screws firmly with the Allen key.

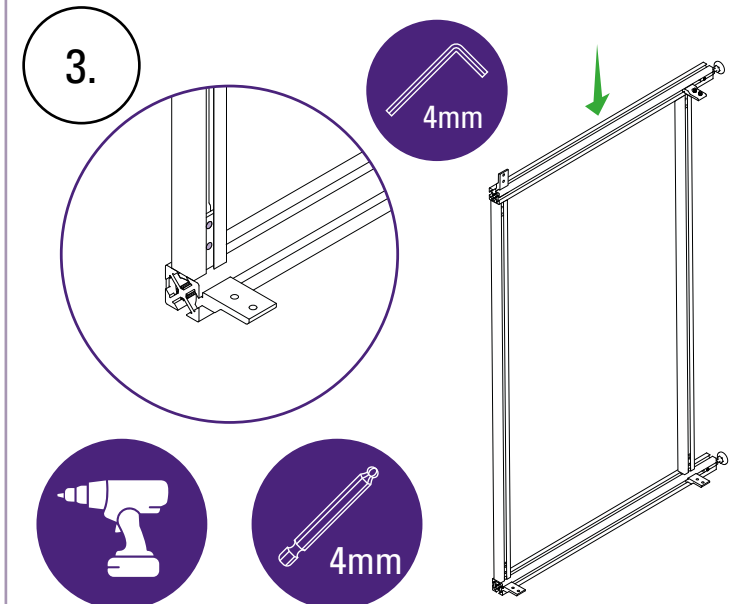

How to build intermediate leg frame

1.

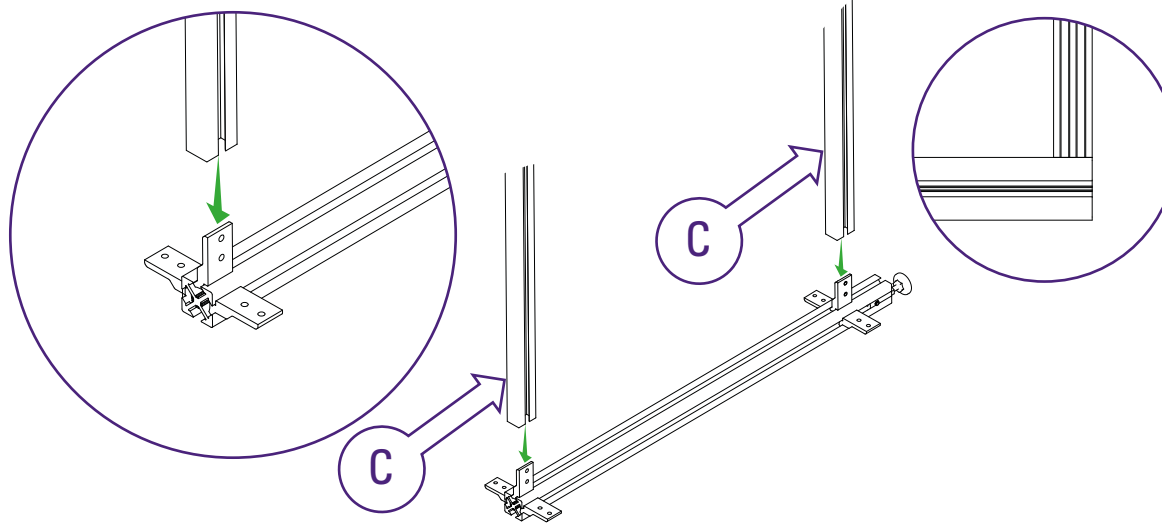

2.

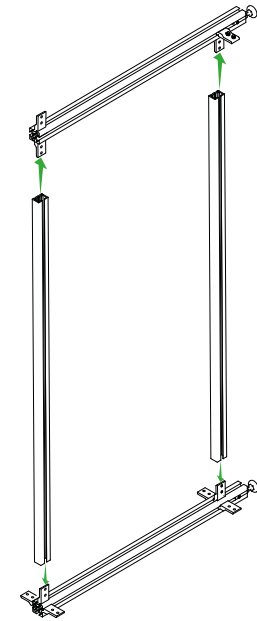

1.

Take middle leg 1 (page 27) and lay one on the floor. Place a beam 2 (part C - page 4) on each bracket. Do not tighten the screws yet.

2.

Place middle leg 2 over the other end of the beams. Press down and ensure all the beam ends are flush against the leg.

3.

Tighten the screws using the 4mm Allen key supplied. There are lots of screws, so you can save time by using a battery operated screwdriver. Whichever method you use, fasten the screws firmly with the Allen key.

3.

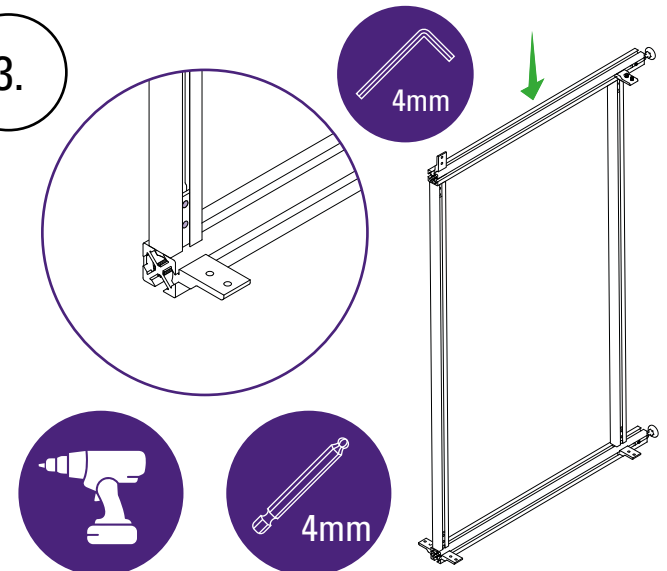

How to build right hand leg frame

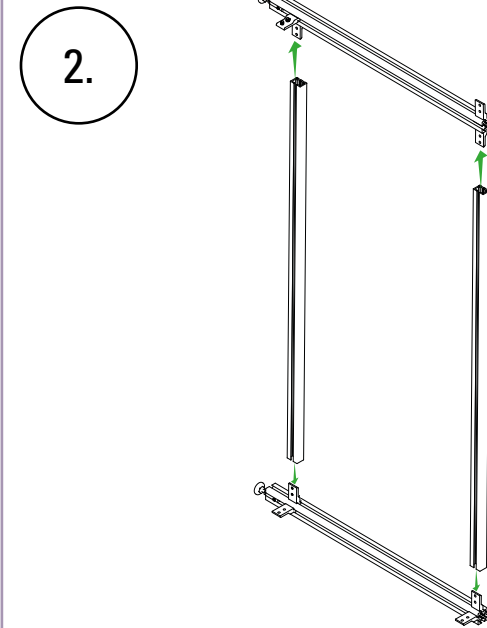
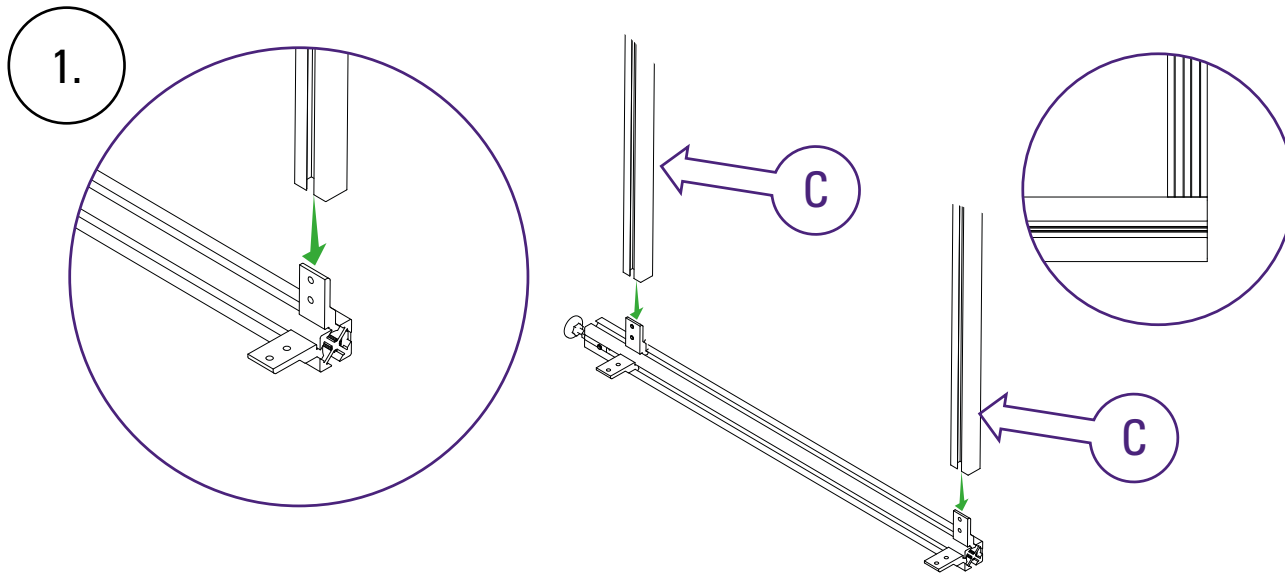

1. Take corner leg 1 (page 27) and lay one on the floor. Place a beam 2 (part C - page 4) on each bracket. Do not tighten the screws yet.

2. Place corner leg 3 over the other end of the beams. Press down and ensure all the beam ends are flush against the leg.

3. Tighten the screws using the 4mm Allen key supplied. There are lots of screws, so you can save time by using a battery operated screwdriver. Whichever method you use, fasten the screws firmly with the Allen key.

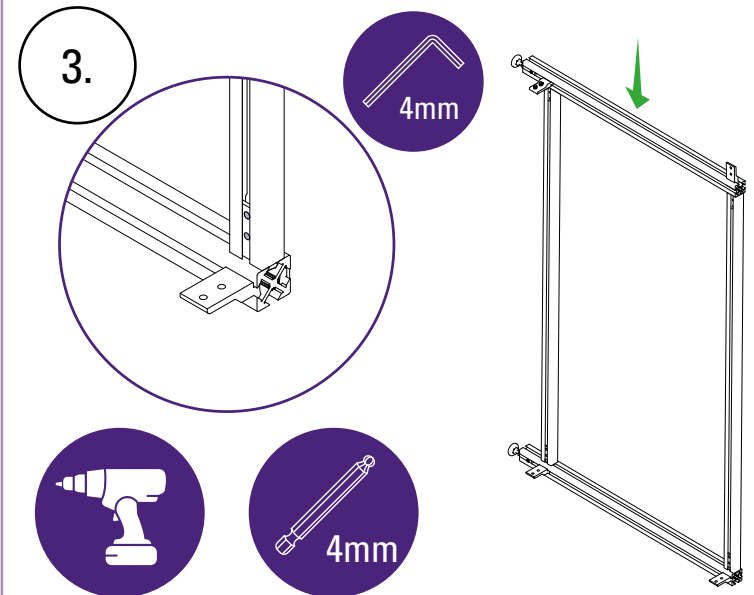

Make the cantilever corners

1.

Cantilever corner

Cantilever middle

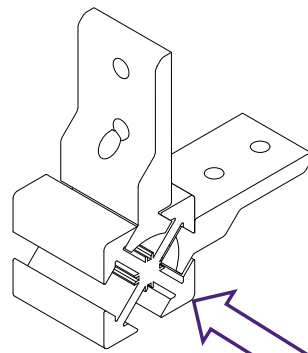

F

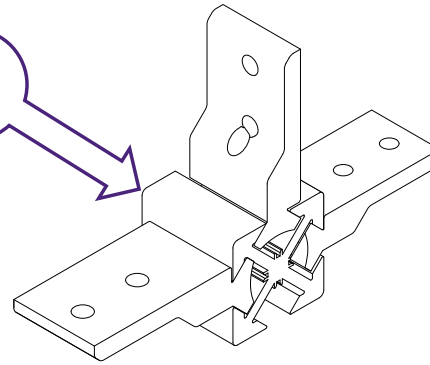

F

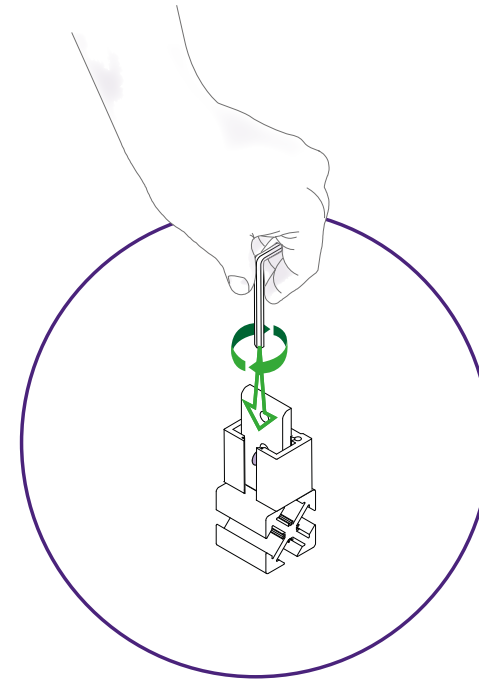

Unit Type	Cantilever corner	Cantilever middle
SFB110	2	0
SFB160 / SFB210 / SFB260	2	1
SFB310 / SFB360 / SFB410	2	2
SFB460 / SFB510	2	3

1.

Assemble cantilever joiners and corner brackets as shown. Ensure screws are fully tightened (see page 25). If available hold the cantilever joiner in a vice whilst tightening.

Make the cantilever joints (1/3)

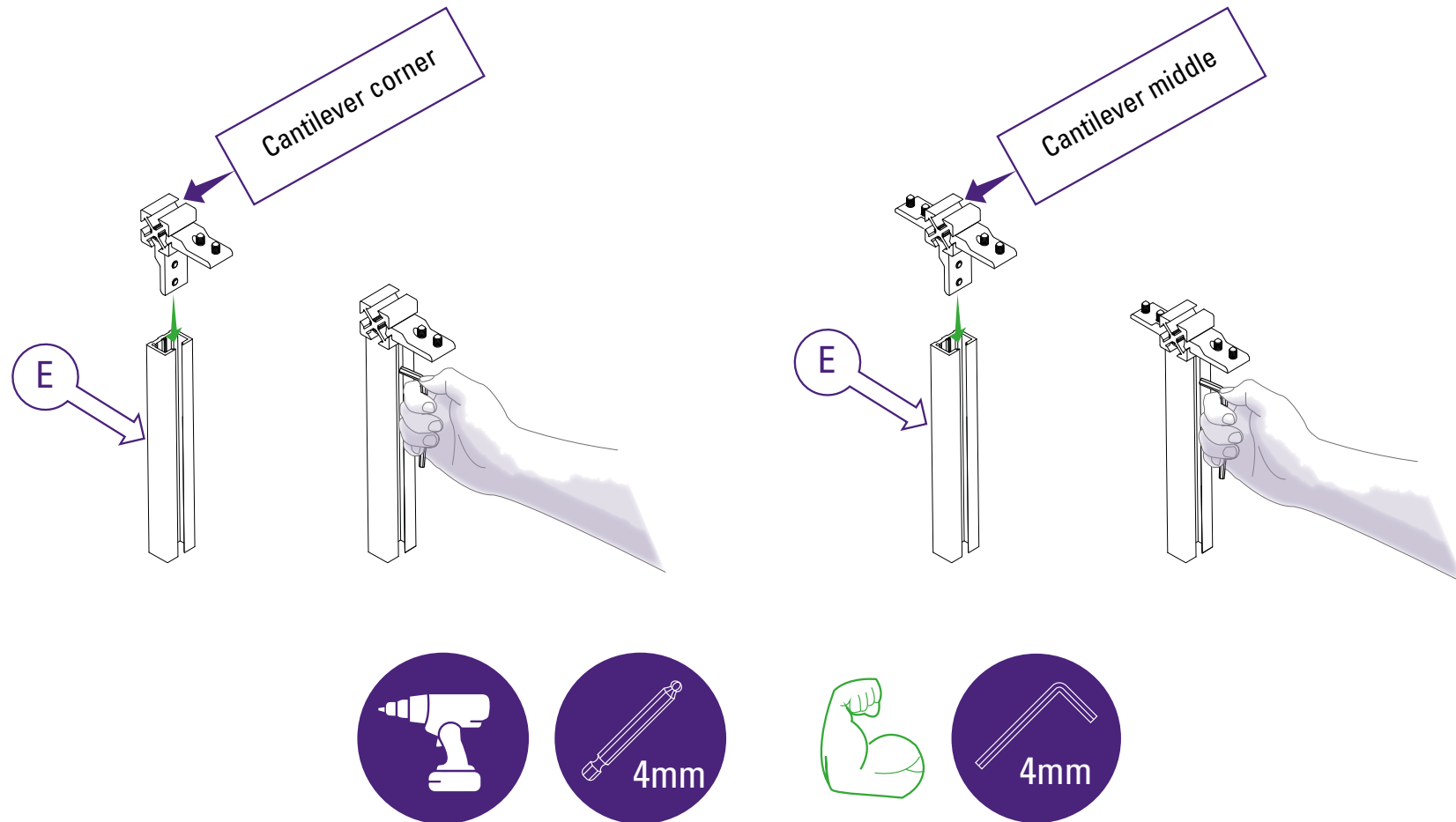

2.

Attach the cantilever corners and cantilever middle to the cantilever arm (part E - page 4). Firmly tighten the screws.

Make the cantilever joints (2/3)

3.

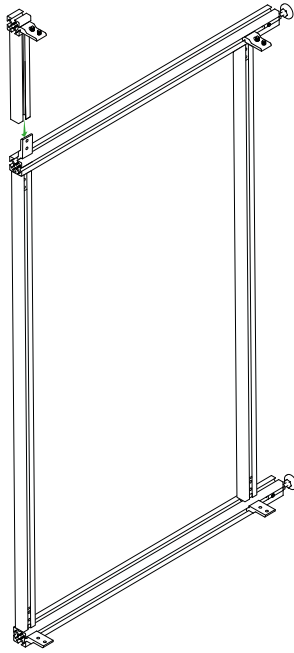

4.



5.

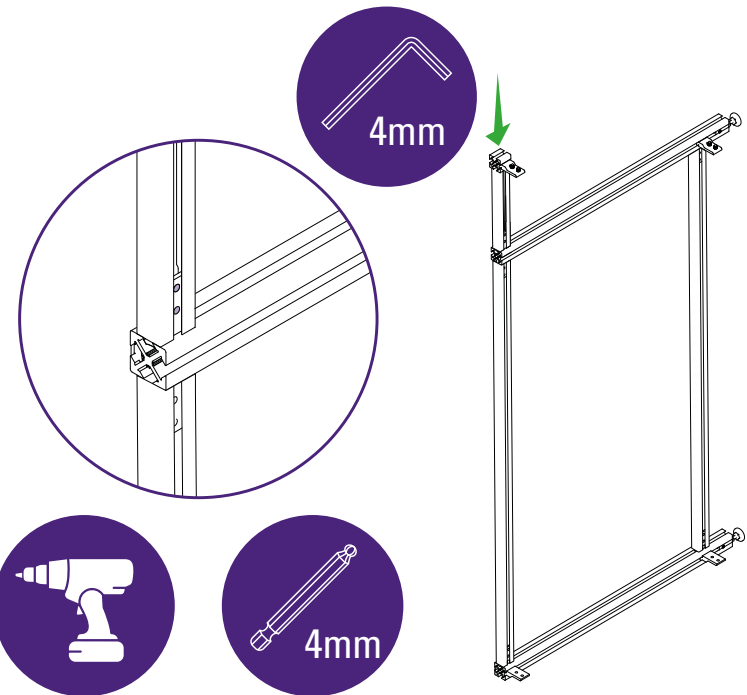

3. Fix the cantilever corner assembly to the left and right hand leg frames.

4. Ensure the brackets on the cantilever corner assembly are pointing in the same direction as the brackets on the frame.

5. Fully tighten all screws (see page 25).

Make the cantilever joints (3/3)

6.

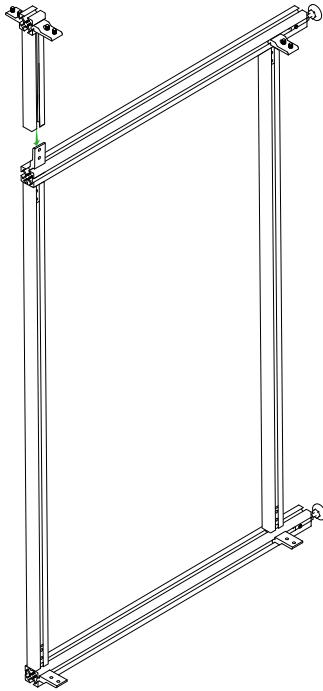

7.



8.

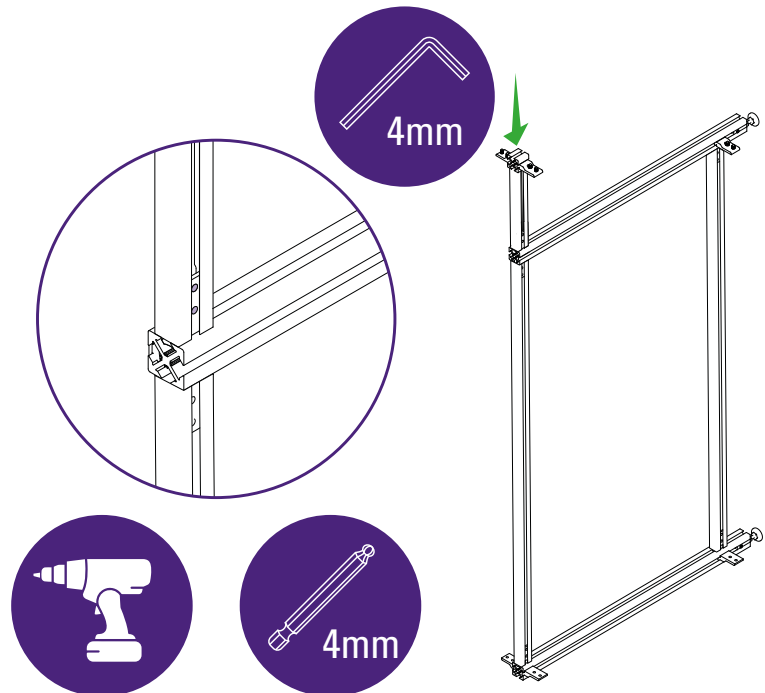

6.

Fix the cantilever middle assembly to the intermediate leg frames.

7.

Ensure the brackets on the cantilever corner assembly are pointing in the same direction as the brackets on the frame.

8.

Fully tighten all screws (see page 25).

Assemble the bench upside down (1/4)

1.

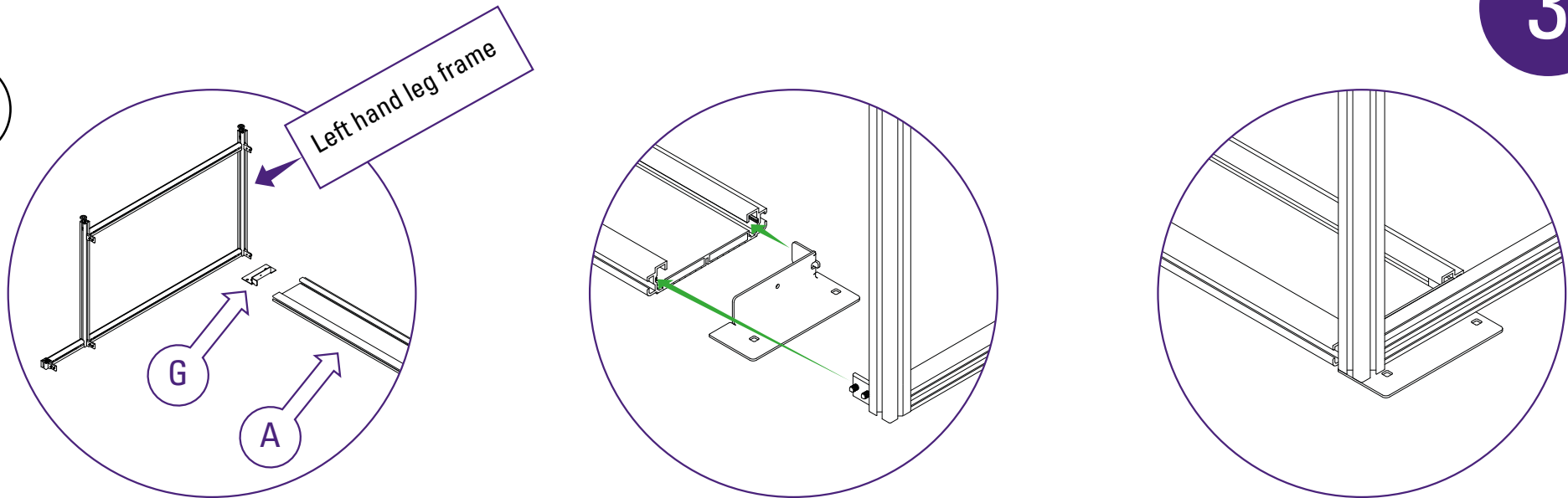

The bench is assembled up side down then turned over when complete

1.

Place a bench edge (part A - page 4), flat side down, on the floor together with the left support plate (Part G) and left hand leg frame. Slide the parts together.

2.

Place three beams on the remaining brackets.

2.

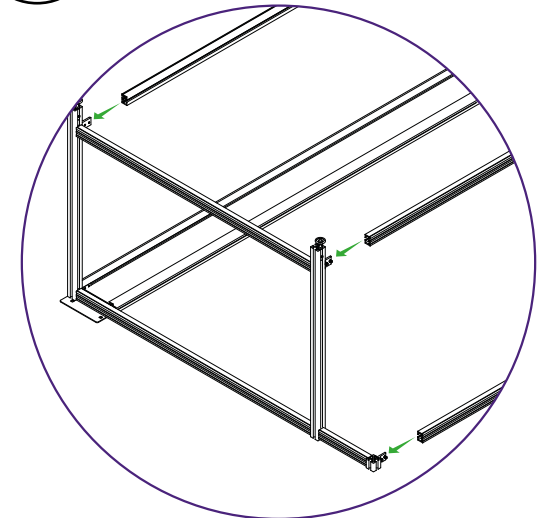

IMPORTANT: Do not tighten any screws at this stage. Details for tightening screws on page 38.

Assemble the bench upside down (2/4)

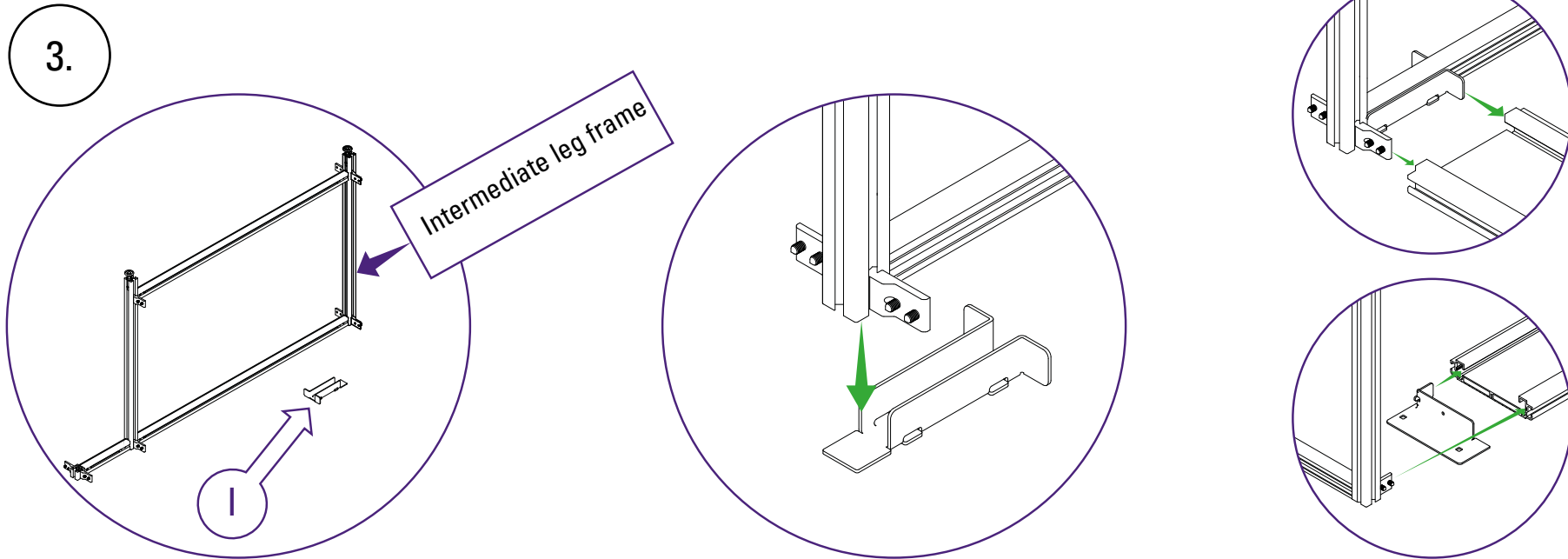

IMPORTANT: If constructing a SFB110, substitute intermediate leg frame for right hand leg frame.

3. Place an intermediate leg frame onto an intermediate support plate (part I) and slide so the bracket just enters 1cm into the bench edge (part A).
4. Align the other three beams and push the frame into position.

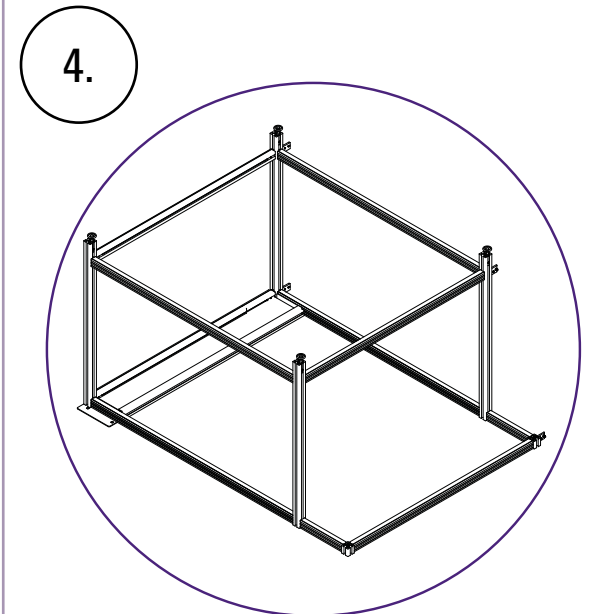

Assemble the bench upside down (3/4)

5.

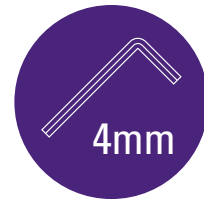
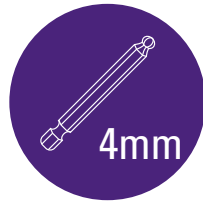
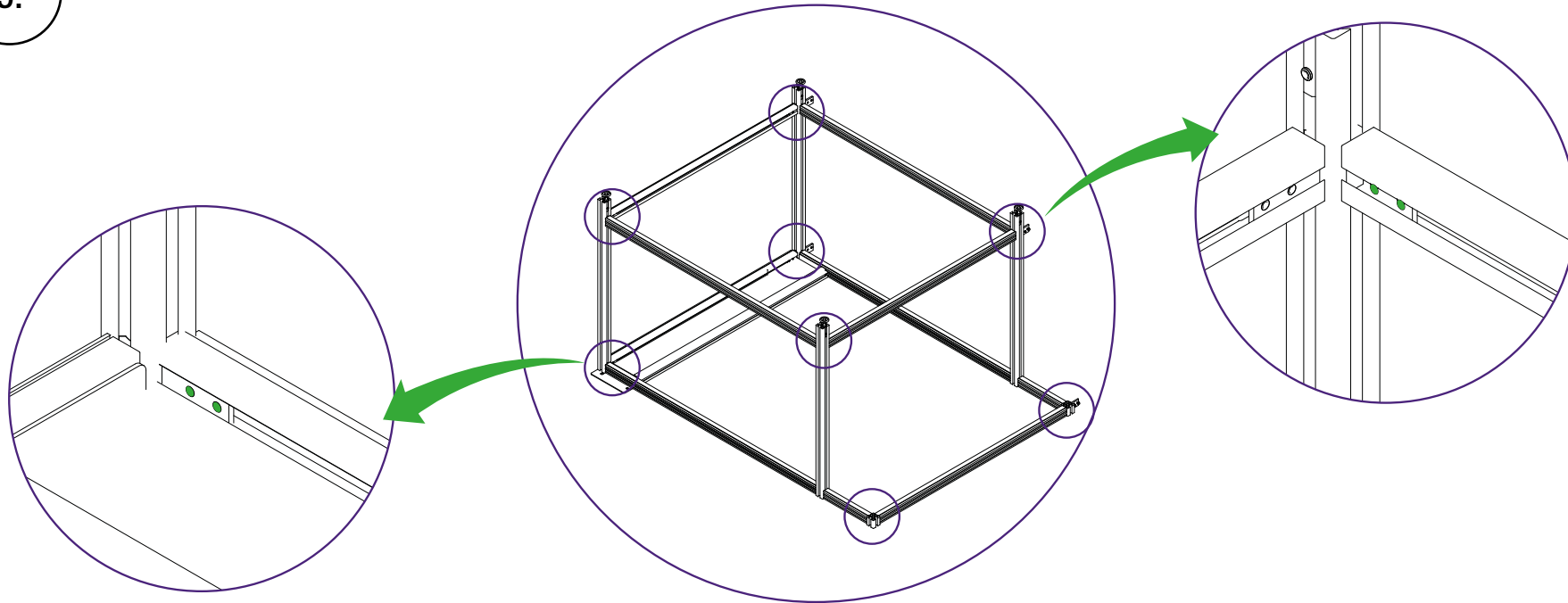

5.

Tighten the remaining loose screws in this section firmly (as shown on page 25).

6.

Continue to build your bench in this way until you reach the end.

6.

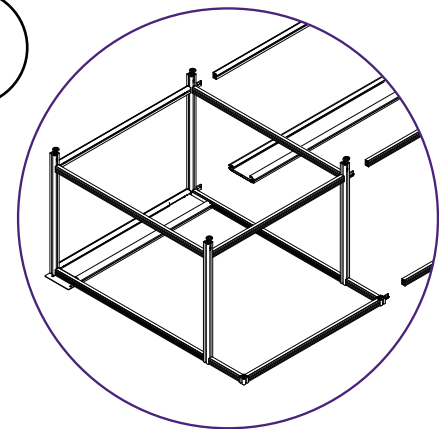

Assemble the bench upside down (4/4)

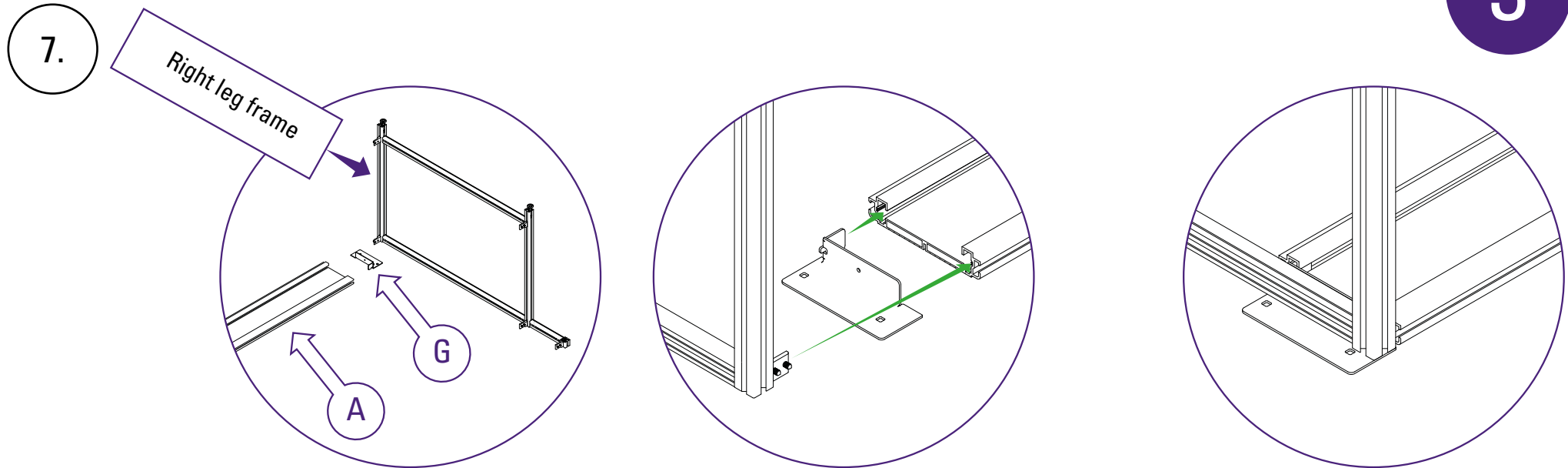

7. To complete your bench assembly, place a right hand leg frame onto an right support plate (part H) and slide so the bracket just enters 1cm into the bench edge (part A).

8. Align the other three beams and push the frame into position. Tighten all screws fully, checking that there are no gaps.

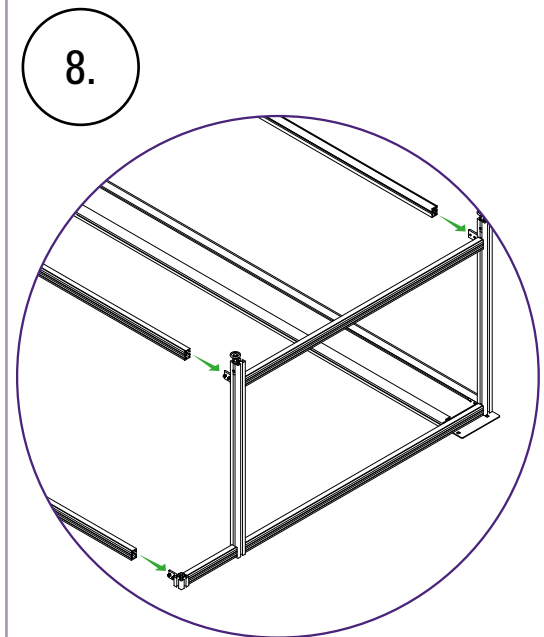

Flip the bench over once assembled

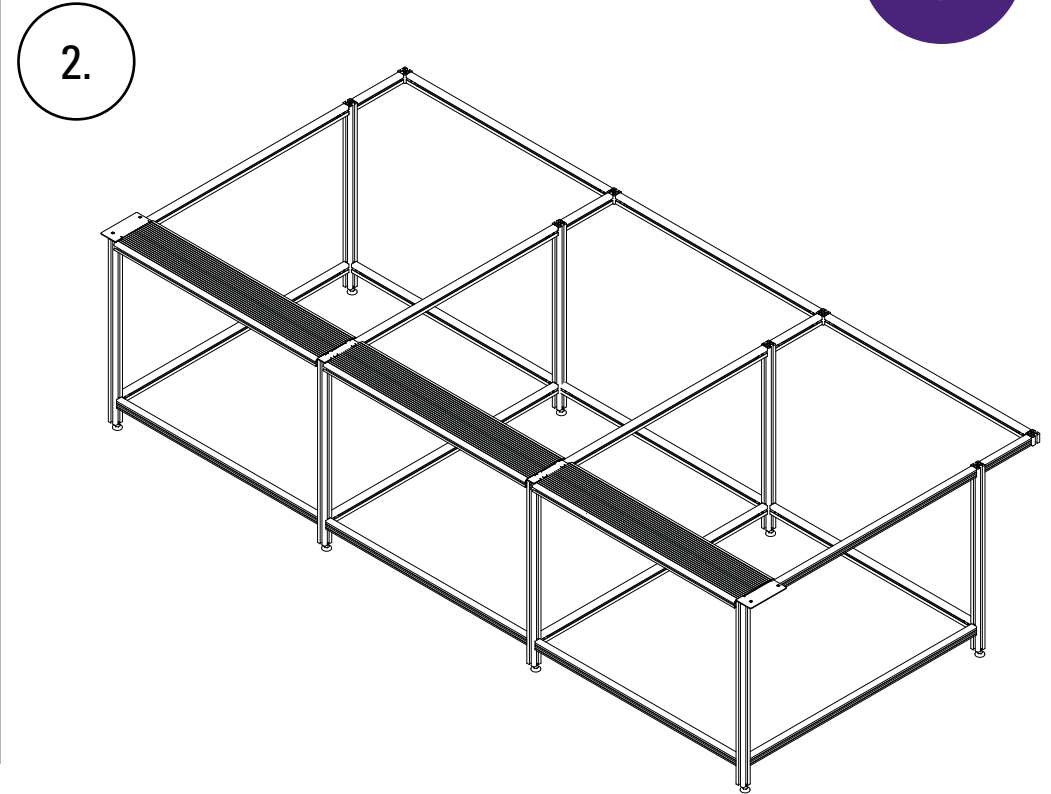
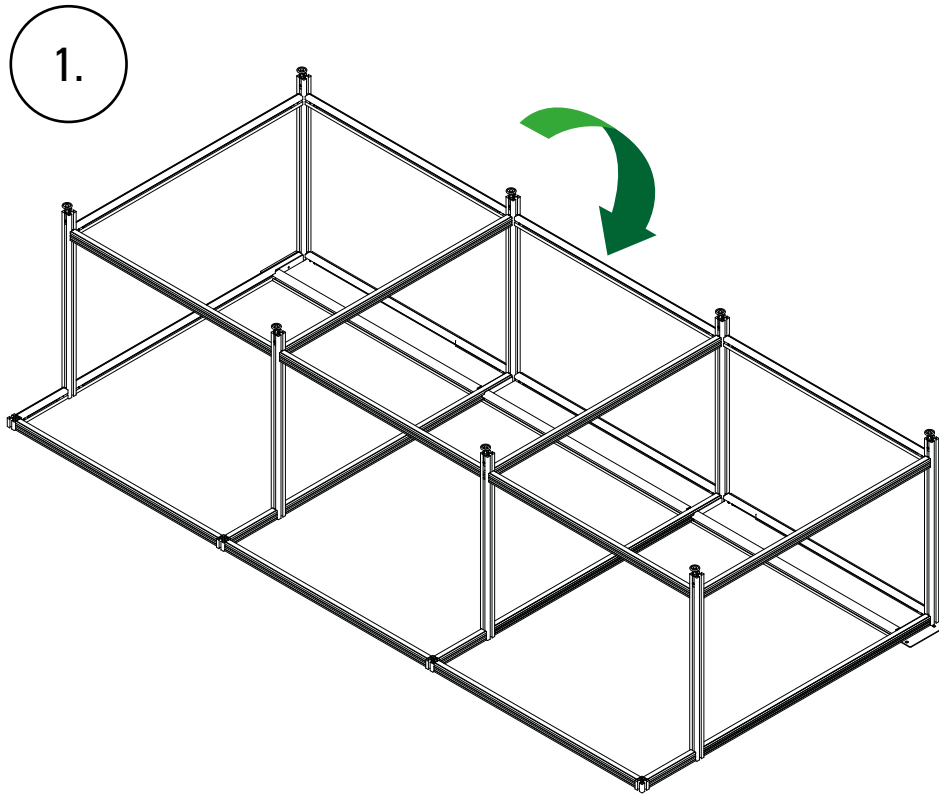

Turn the bench over by rolling onto its front face and then onto its feet. Place in its final working position

IMPORTANT: Before the cutter is mounted it is essential the bench edge extrusions are all flat to within 3mm. Using a spirit level follow the sequence in section 4.



Finish



Levelling the bench (1/5)

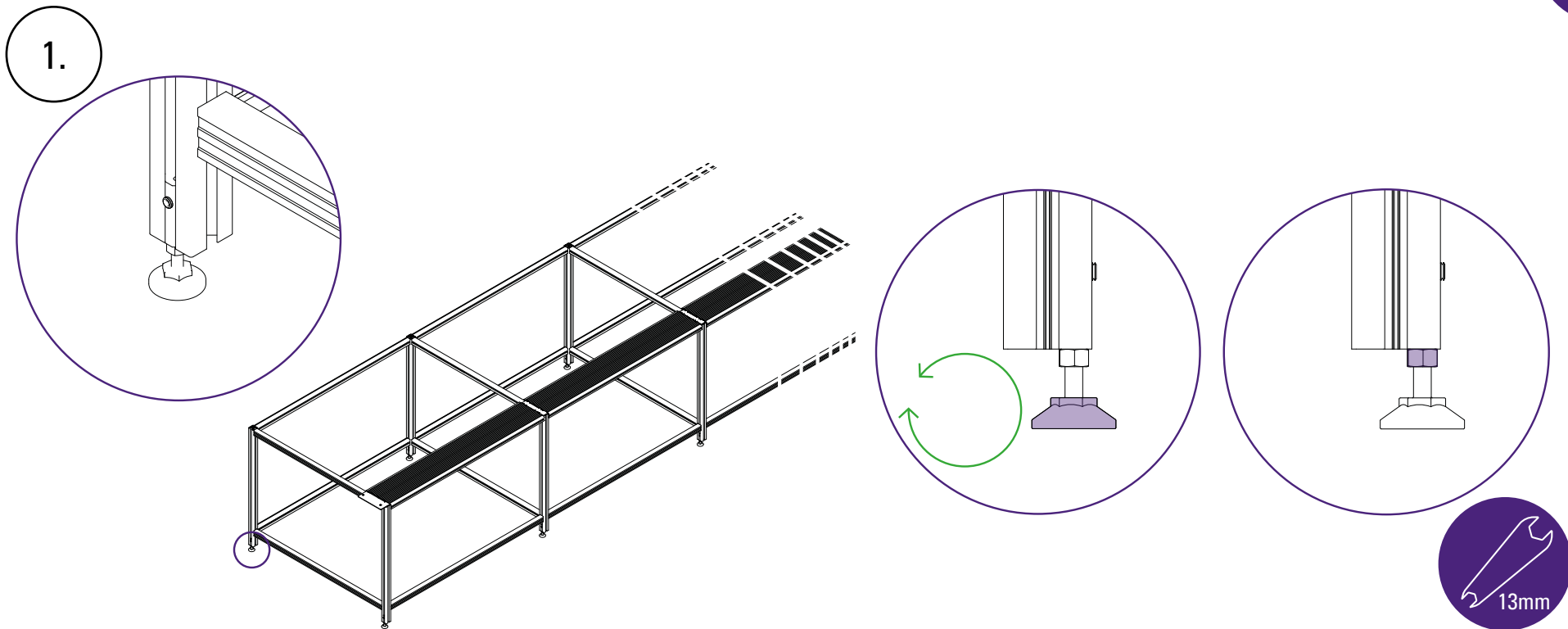

1. Adjust foot by twisting the base so it is about halfway extended. Lock in place using the 13mm spanner.

Levelling the bench (2/5)

2.

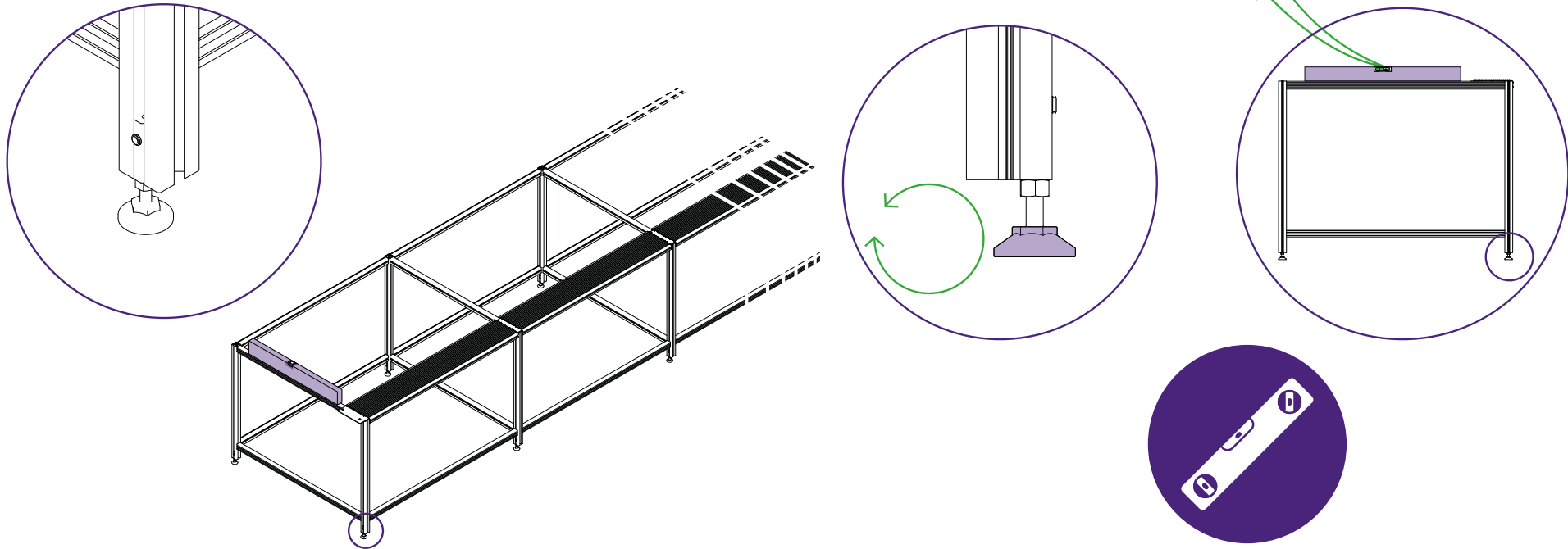

2.

Place the spirit level in highlighted position and adjust highlighted foot to bring it to level.

IMPORTANT: Do not tighten the nut on the foot yet. This action is to be carried out on page 46.

Levelling the bench (3/5)

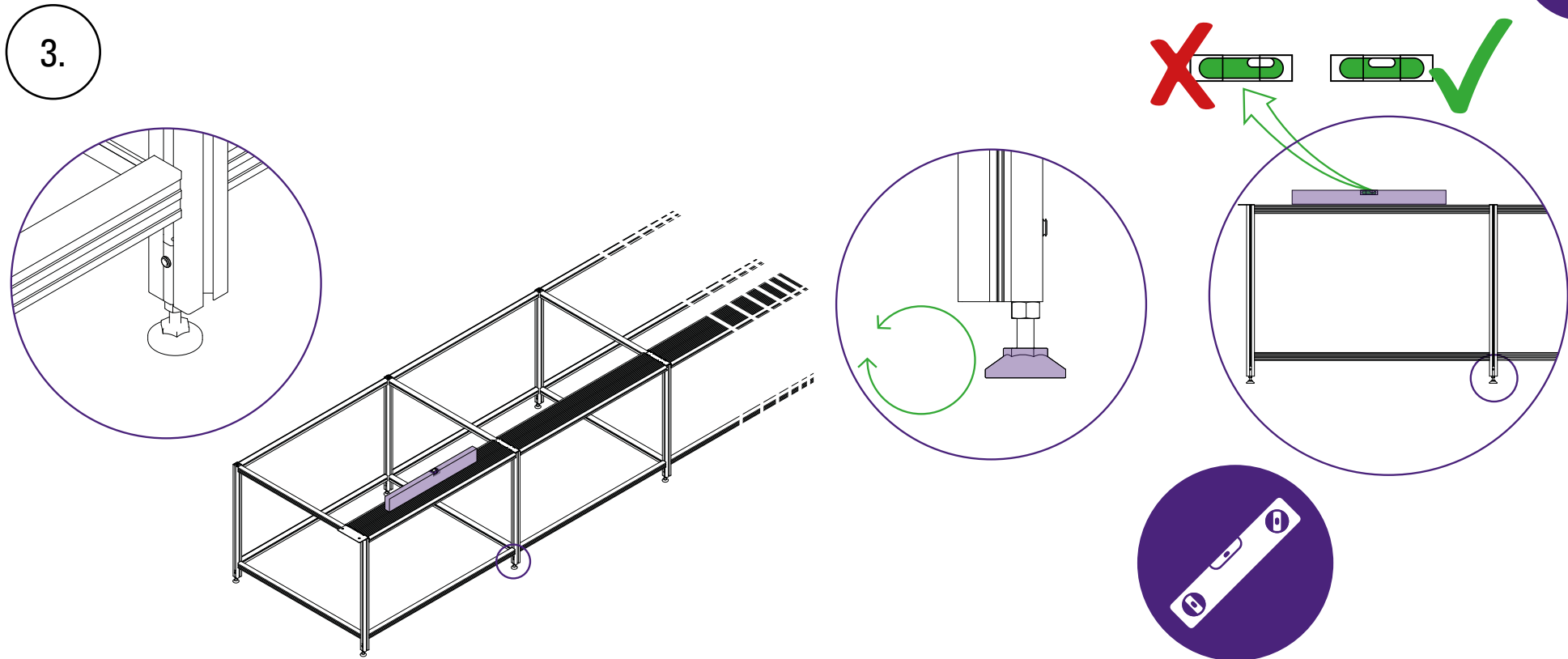

3. Place the spirit level in highlighted position and adjust highlighted foot to bring it to level.

IMPORTANT: Do not tighten the nut on the foot yet. This action is to be carried out on page 46.

Levelling the bench (4/5)

4.

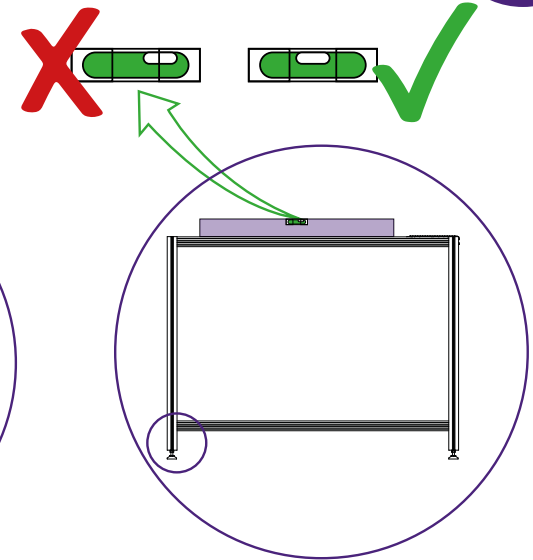
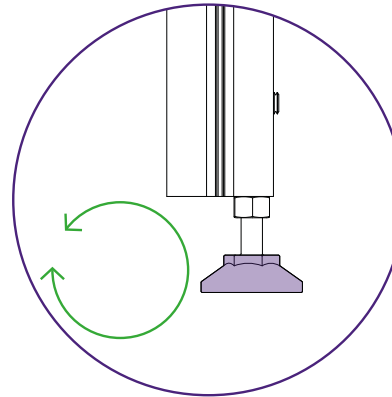
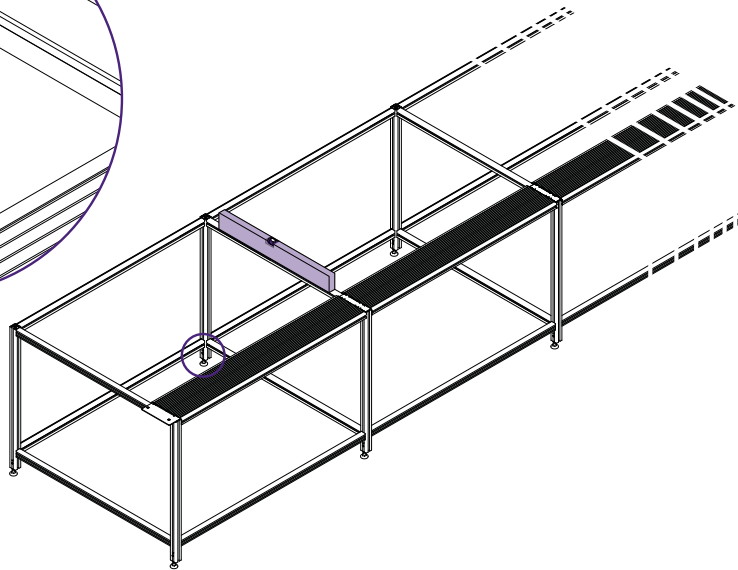
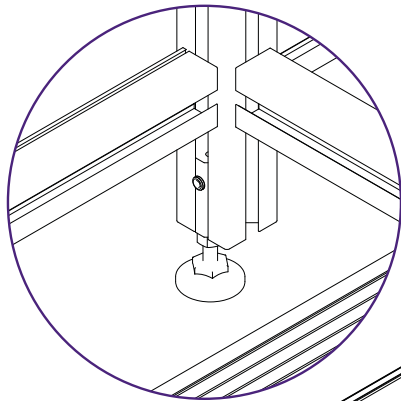

4.

Place the spirit level in highlighted position and adjust highlighted foot to bring it to level.

IMPORTANT: Do not tighten the nut on the foot yet. This action is to be carried out on page 46.

Levelling the bench (5/5)

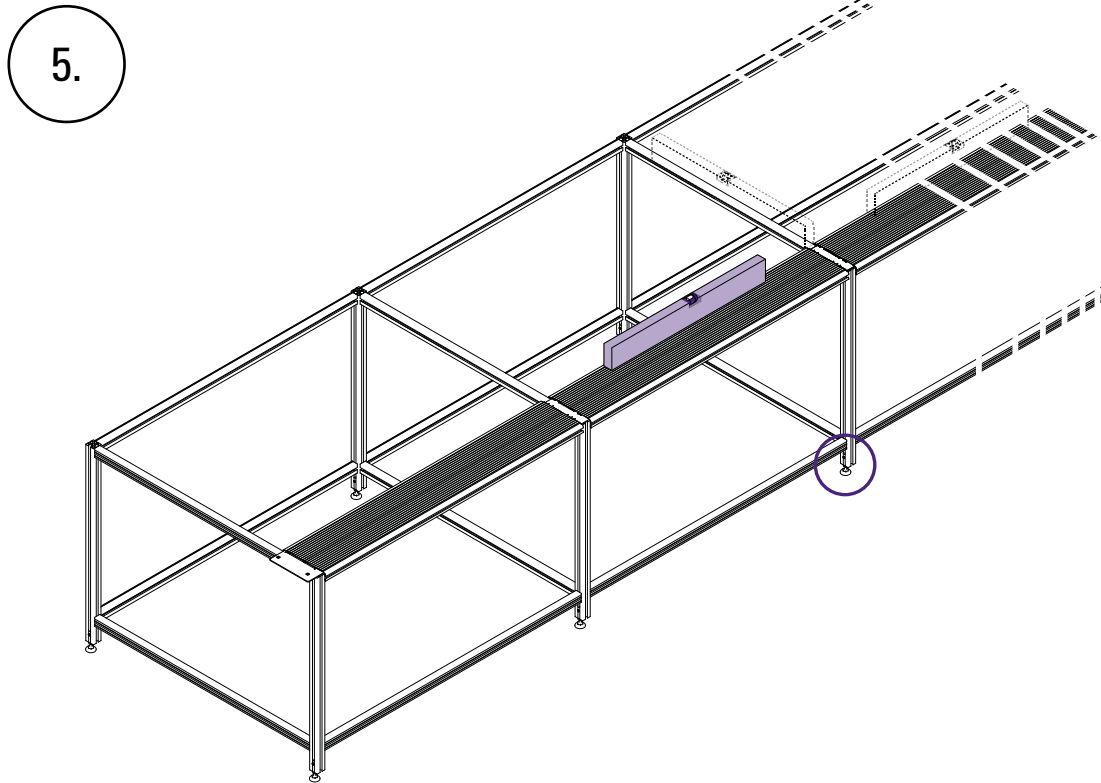

6.

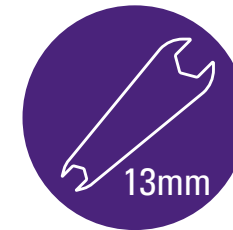
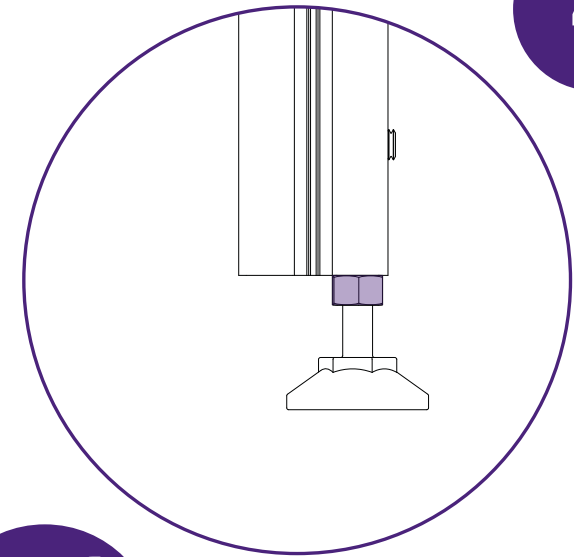

5. Repeat steps 3 & 4 from pages 44-45 until you reach the end of the bench.

6. Once complete and your bench is levelled, lock all feet in position using the 13mm spanner provided.

Preparing the worktop

Worktop width = 1220mm (8') or 1525mm (10') dependent upon cantilever		
Unit Type	3050mm (10') long boards	2440mm (8') boards
SFB110	1440mm (56 5/8")	1440mm (56 5/8")
SFB160	1940mm (76 3/8")	1940mm (76 3/8")
SFB210	2440mm (96")	2440mm (96")
SFB260	2940mm (115 5/8")	2x1470 (2x 57 3/4")
SFB310	1160mm + 2280mm (45 5/8" + 89 3/4")	1160mm + 2280mm (45 5/8" + 89 3/4")
SFB360	1327mm + 2614mm (52 1/8" + 102 7/8")	2x 1327mm + 1287mm (2x 52 1/8" + 50 5/8")
SFB410	1493mm + 2946mm (58 3/4" + 115 7/8")	2x 1493mm + 1453mm (2x 58 3/4" + 57 1/8")
SFB460	2x2470mm (2x 97 1/8")	2x1255mm + 2x1215mm (2x 48 1/8" + 2x 47 3/4")
SFB510	2x2720mm (2x 107")	2x1380mm + 2x 1340mm (2x 54 1/4" + 2x 52 3/4")

The worktop should be cut from 18mm (3/4") thick MDF or plywood, to the exact size specified above. These sizes have been designed to ensure that all joints are directly over a beam. Do not use over-sized boards because excessive overhang can interfere with the cutter when you use the purple cutting strip.

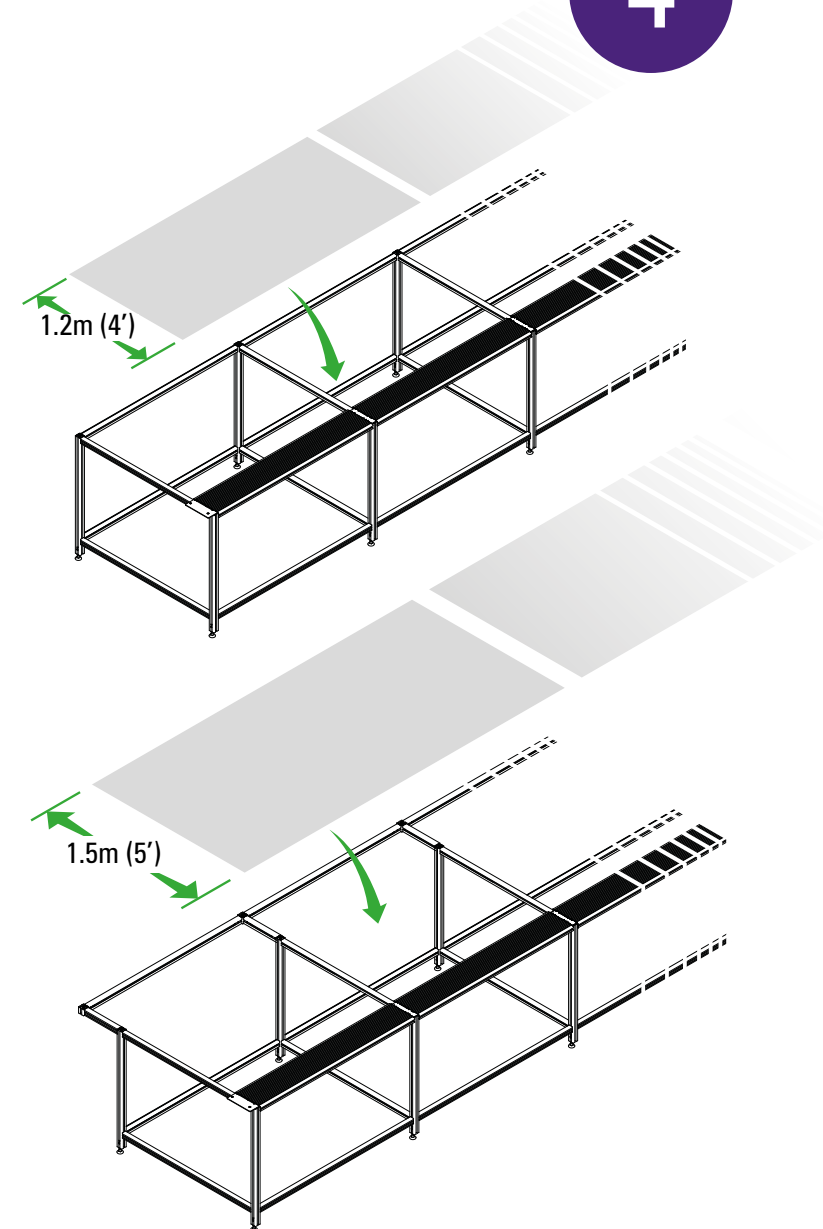

Fixing the worktop

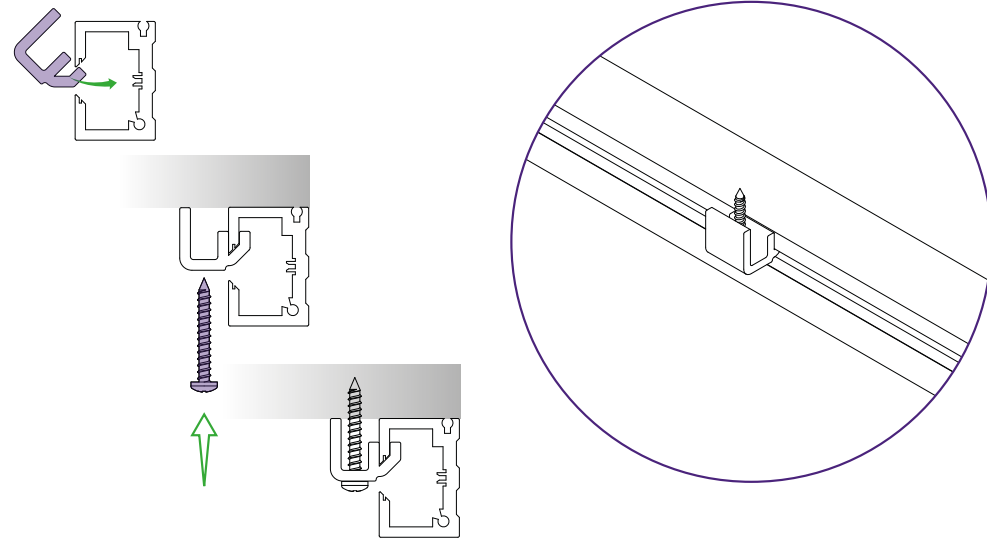
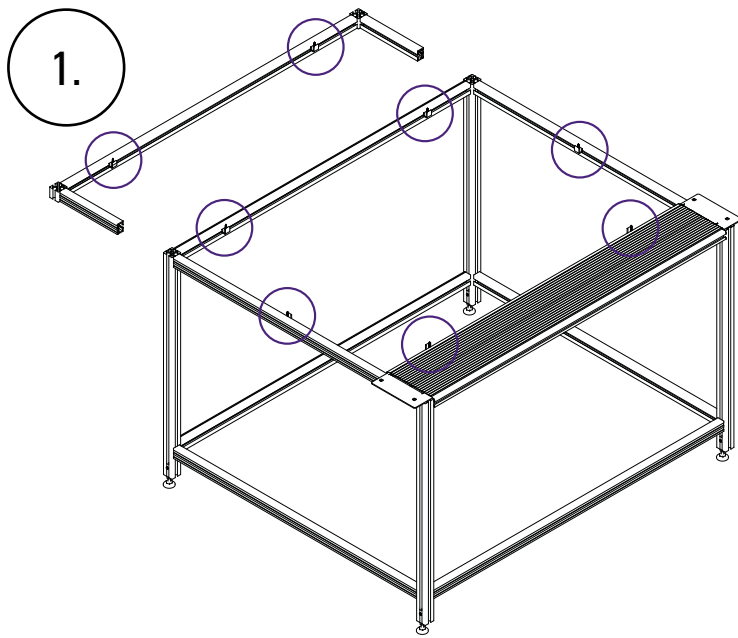

IMPORTANT: Fit the SmartFold cutter before fitting the worktop.

Evenly space the worktop fixing brackets and screws to fasten the worktop down to the bench framework and bench edge extrusion as shown.

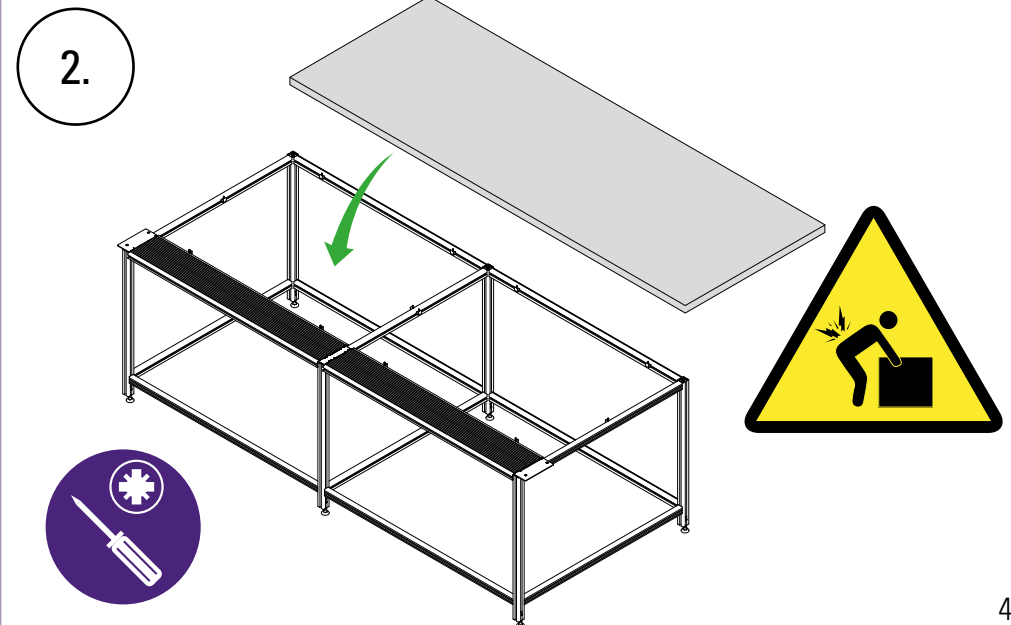

Fitting a glass worktop

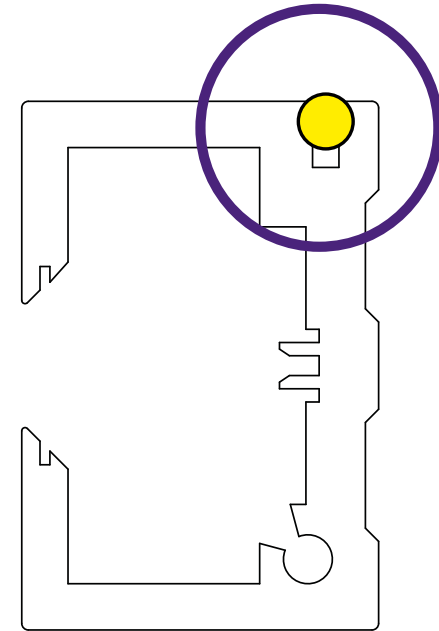
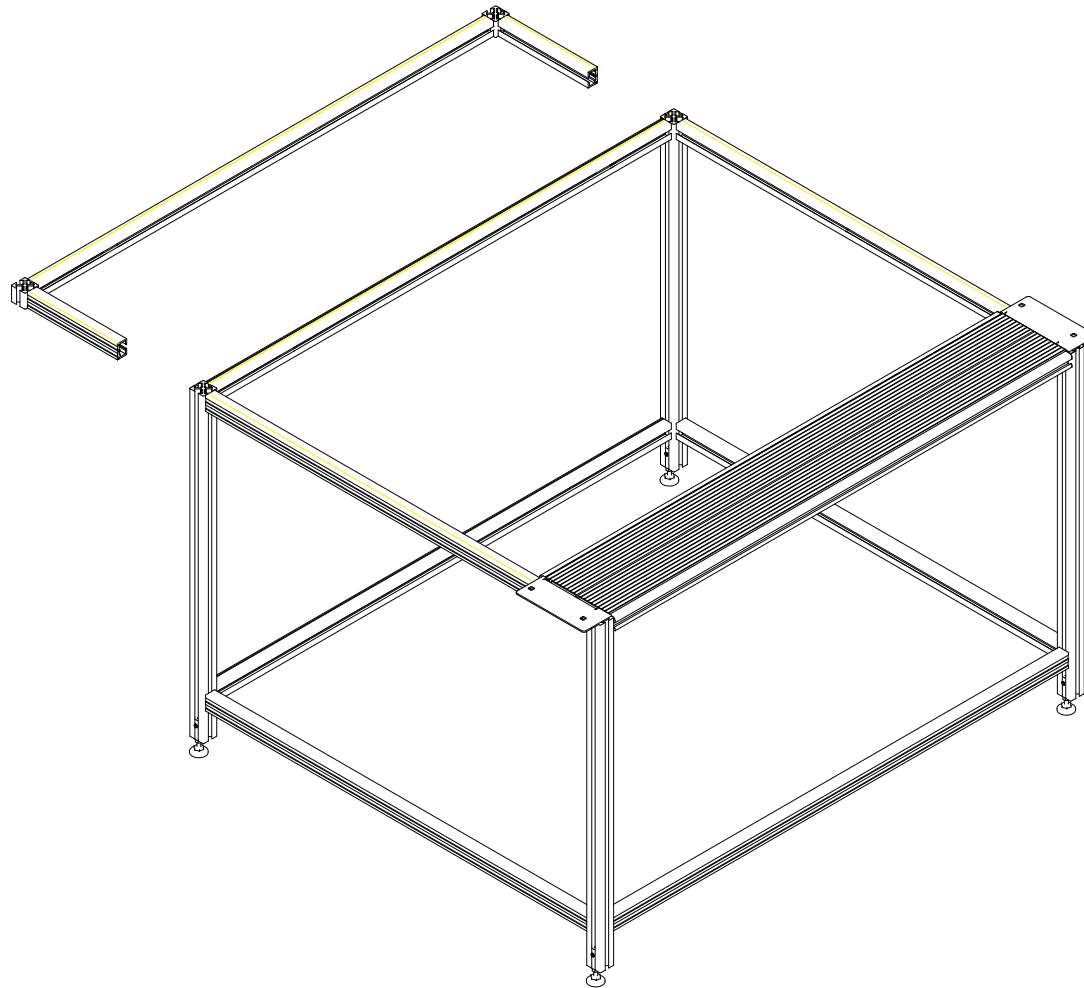

Evenly space white silicone chord in the highlighted groove ensuring that it is firmly in place before gently lowering glass surface onto the bench.

Note: White silicone chord is sold separately please visit our website or contact your dealer for more details.

Maintenance

1.

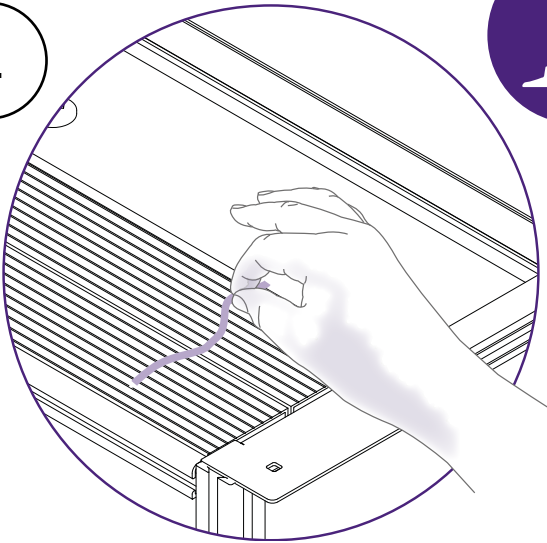

2.

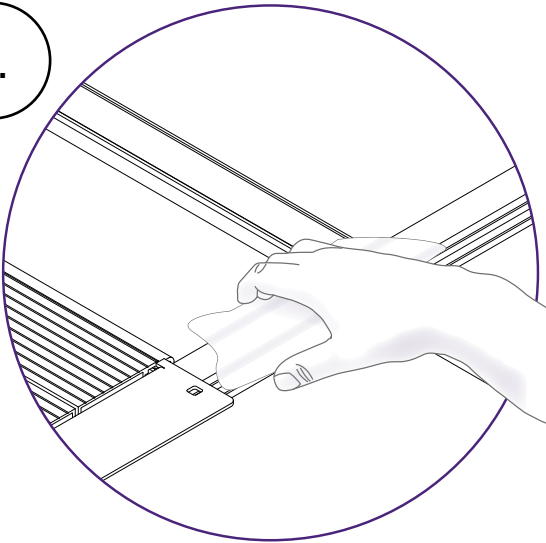

+



1.

Regularly remove offcuts and clean with a vacuum cleaner.

2.

Moisten a cloth in diluted detergent to remove any marks.

IMPORTANT: Do not use harsh chemicals or solvents.

3.

If the bench is not rigid ensure all grub screws are fully tightened. If the brackets are not fixed tightly to the leg you may need to take the bench apart to do this.

3.

