

KEENCUT

JAVELIN & PRACTIK

INSTRUCTIONS

Thankyou for choosing the Keencut Javelin/Praktik.
Every effort has been made to bring you a superbly
built product with the promise of many years of
good service.

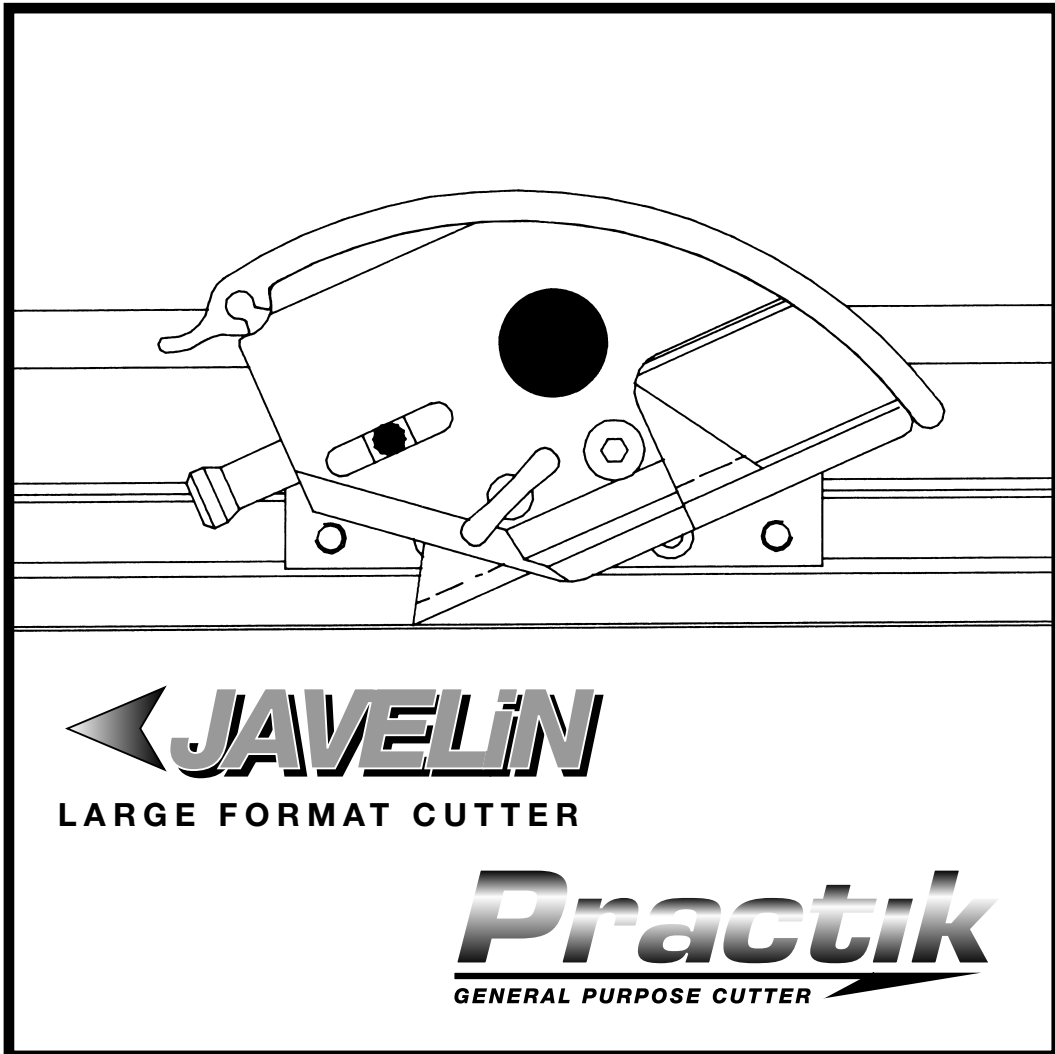

Keencut - the world's finest cutting machines

Keencut Limited, Tyson Courtyard, weldon South Industrial Estate,
Corby, Northants, ENGLAND NN18 8AZ.
Telephone: 01536 263158 Facsimile: 01536 204227
E-mail: info@keencut.co.uk Website: www.keencut.co.uk

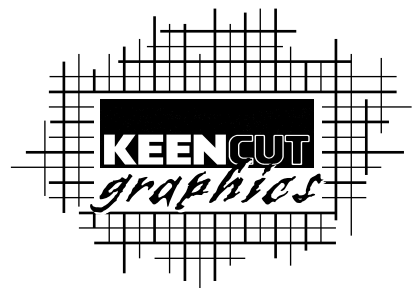

**SAFETY
WARNING**

Only lift or move the Javelin/Practik using the grip on the top edge of the cutter bar. If there is a need to handle the cutter in any other way or to move it away from its cutting bench, the blade must be removed first.

It is essential that the Javelin/Practik is used on a flat surface to cut accurately. A warped or bowed table top can induce a twist in the Javelin/Practik resulting in a bowed cut.

Fitting the Wall Brackets

Space the brackets so that the Javelin/Practik is evenly supported and does not sag, ensure they are securely fixed to the wall.

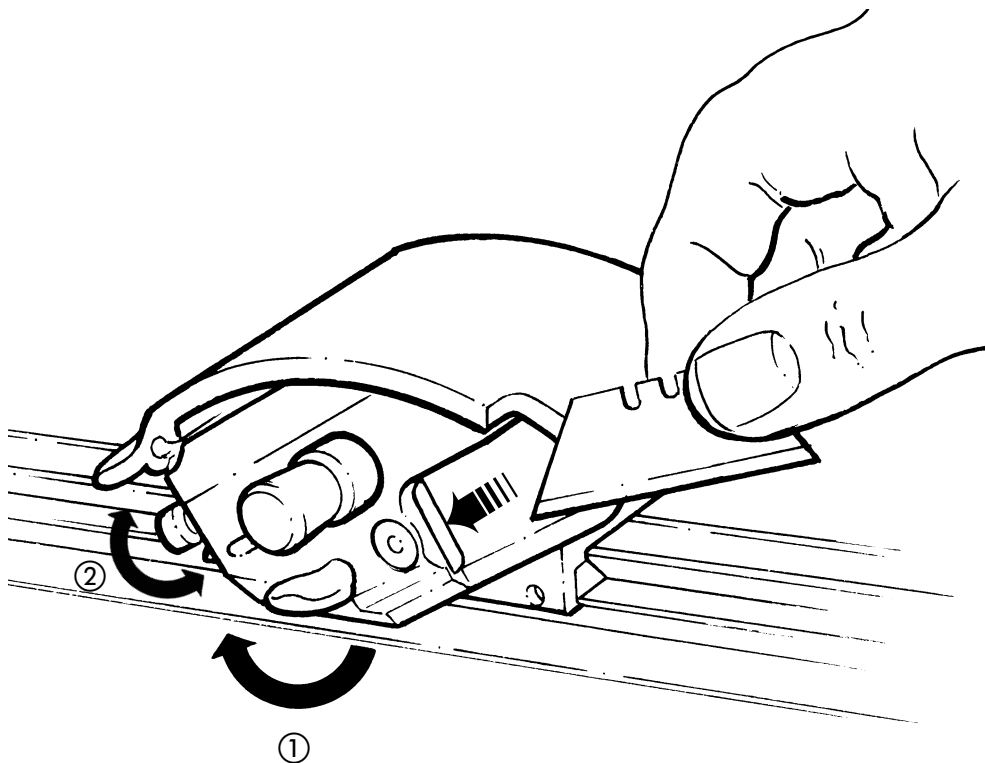
**Inserting and setting the blade**

- ① The blade is inserted from the back of the blade holder, push it fully forward and tighten the wingbolt.
- ② To set the blade for a repeatable cutting depth unclamp the blade and turn the knob at the front of the cutter, clockwise to increase blade depth & counter clockwise to decrease.

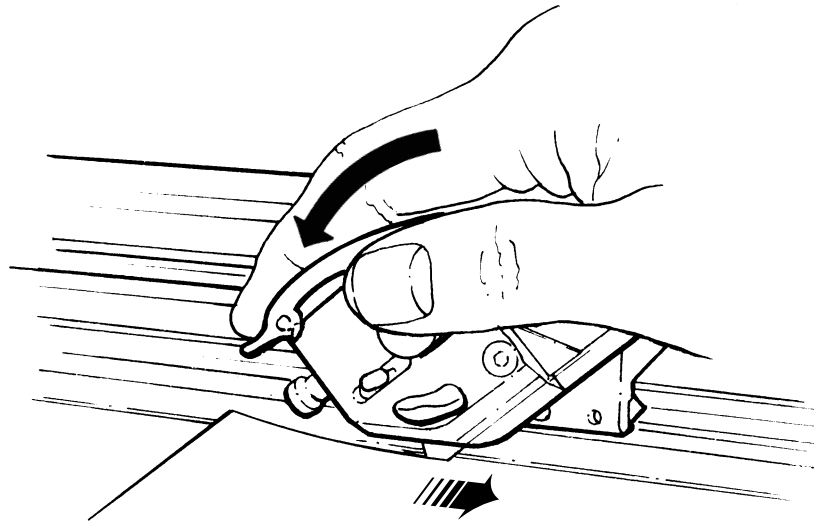

. . . for cutting film and lightweight materials.

Position the material under the Javelin/Practik and align the sight edge with your cutting marks. The Javelin/Practik will cut within 0.5 to 1mm [0.02" to 0.04"] of the sight edge, this small gap allows easier alignment when cutting to the edge of an image. Place your hand on the cutter, as shown, with your finger tips positioned in the groove across the front edge of the cutter. Depress the cutter and pull to cut, there is no need to hold the Javelin/Practik down when cutting lightweight materials.

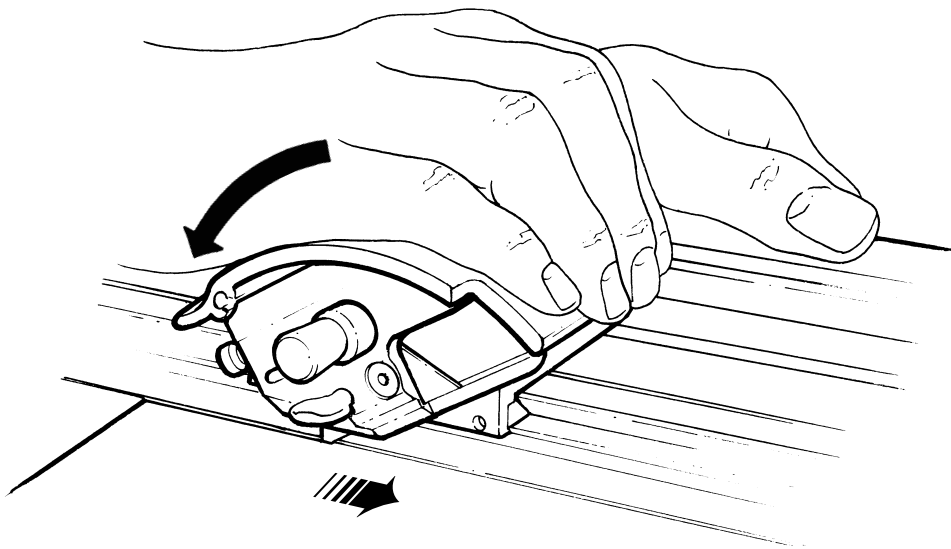

. . . for cutting PVC foamboard and heavyweight materials.

Position the material under the Javelin/Practik and align the sight edge with your cutting marks. The Javelin/Practik will cut within 0.5 to 1mm [0.02" to 0.04"] of the sight edge, this small gap allows easier alignment when cutting to the edge of an image. Place your hand on the cutter, as shown, with the palm of your hand positioned over the groove on the front edge of the cutter. Place your left hand on the finger grip of the straight edge, depress the cutter and push it away from you to cut. Dependant upon the nature and thickness of the material you may need to take more than one cut gradually increasing the depth.

Do not use oil or spirits to lubricate or clean the Javelin/Practik, some of the plastic components and bearings may be damaged.

Cleaning and lubrication

It is good practice to keep a dust sheet over the Javelin/Practik if it is not to be used for extended periods. In any event regularly clean it with a dry cloth, to remove any stubborn stains use a cloth dampened with a little water/detergent.

Should the cutting head slideway require lubrication use a silicon spray or impregnated sponge.

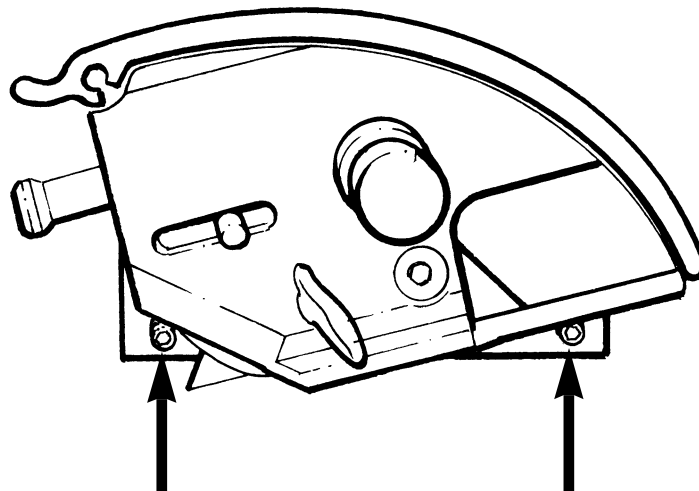

Cutting Head Bearings

The bearings that control the sliding motion of the cutting head are manufactured from a high grade polymer and under normal use will last for an extremely long time. As they settle into position you may find a slight amount of side play, this can be removed by tightening the two adjustment screws.

Should you require any advice or technical information please contact your distributor or Keencut direct.