

KEENCUT TWIN WHEEL CUTTER HEAD

2

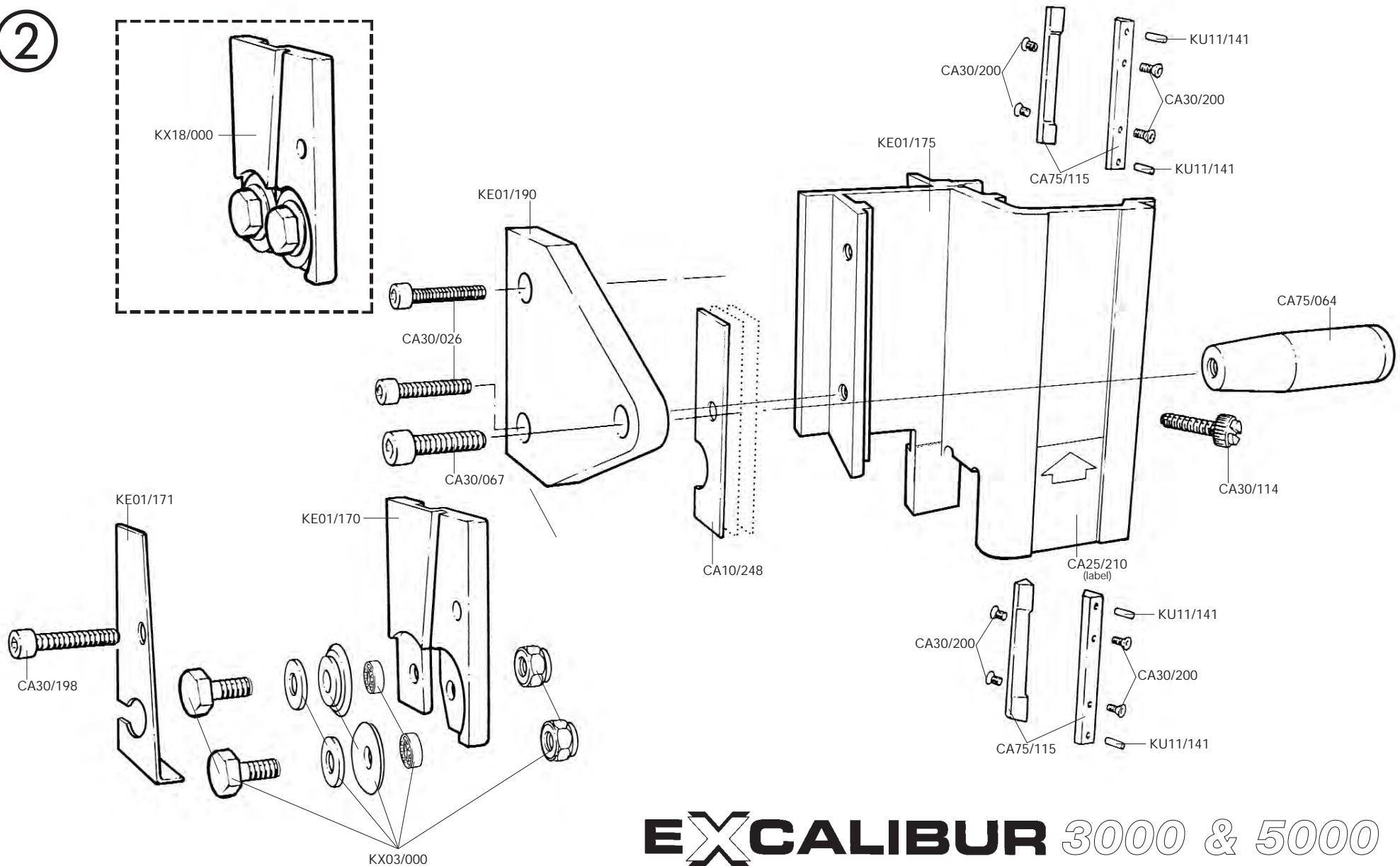

EXCALIBUR 3000 & 5000

KEENCUT SINGLE TOOL CUTTER HEAD

3

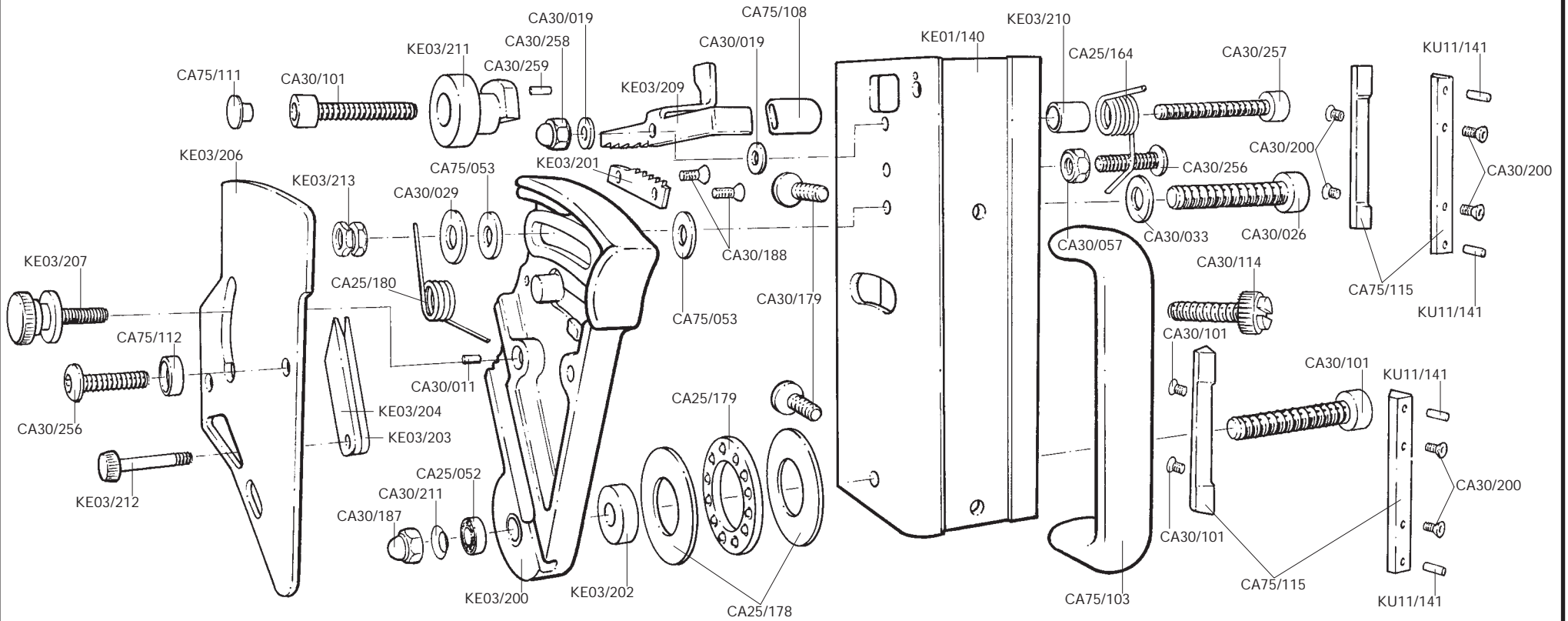

EXCALIBUR 1000 & 3000
(Pre 2008)

KEENCUT

MULTI - CUTTER HEAD

4

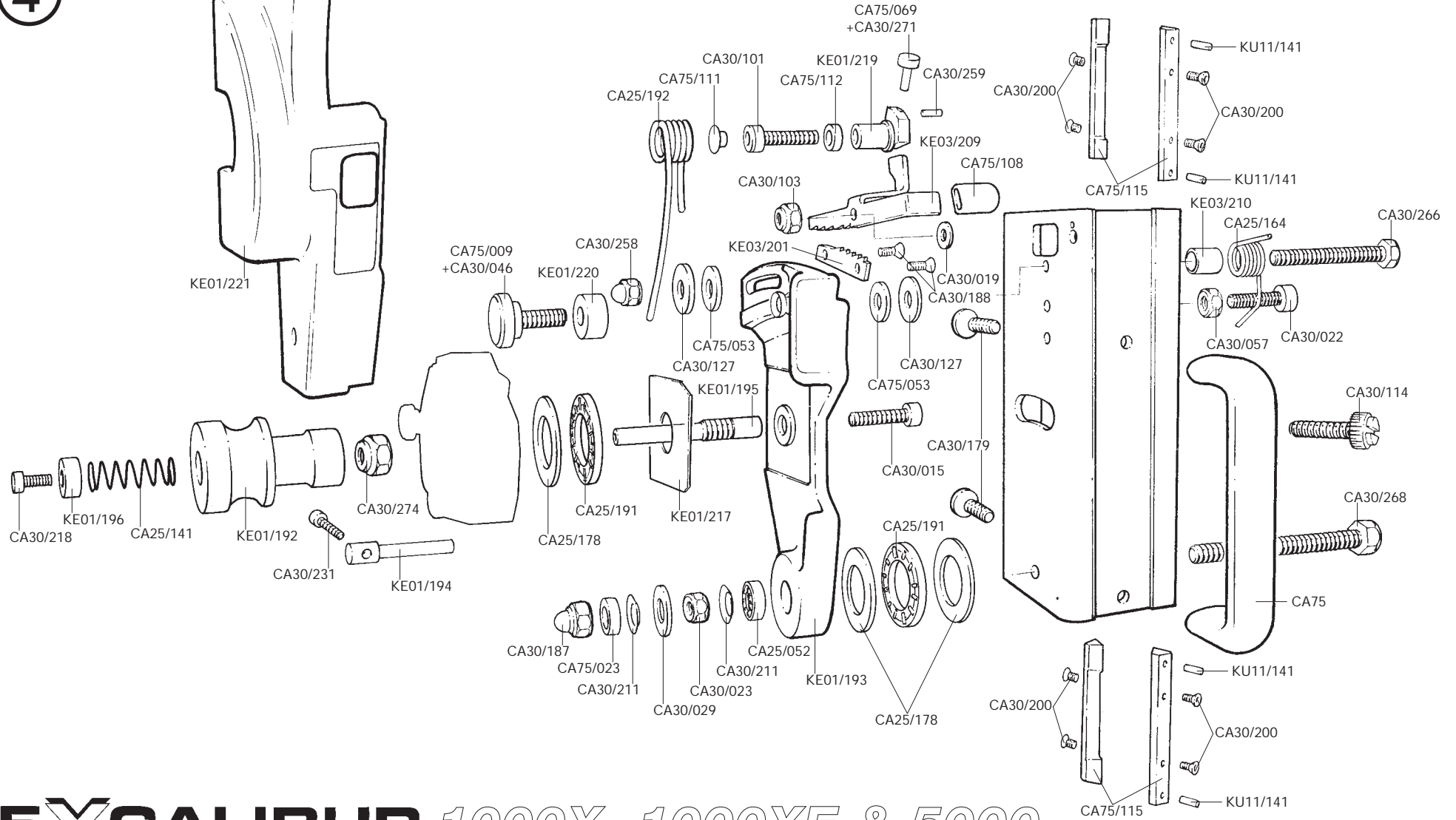

EXCALIBUR 1000X, 1000XE & 5000

KEENCUT

BALANCE WEIGHT ASSEMBLY

6

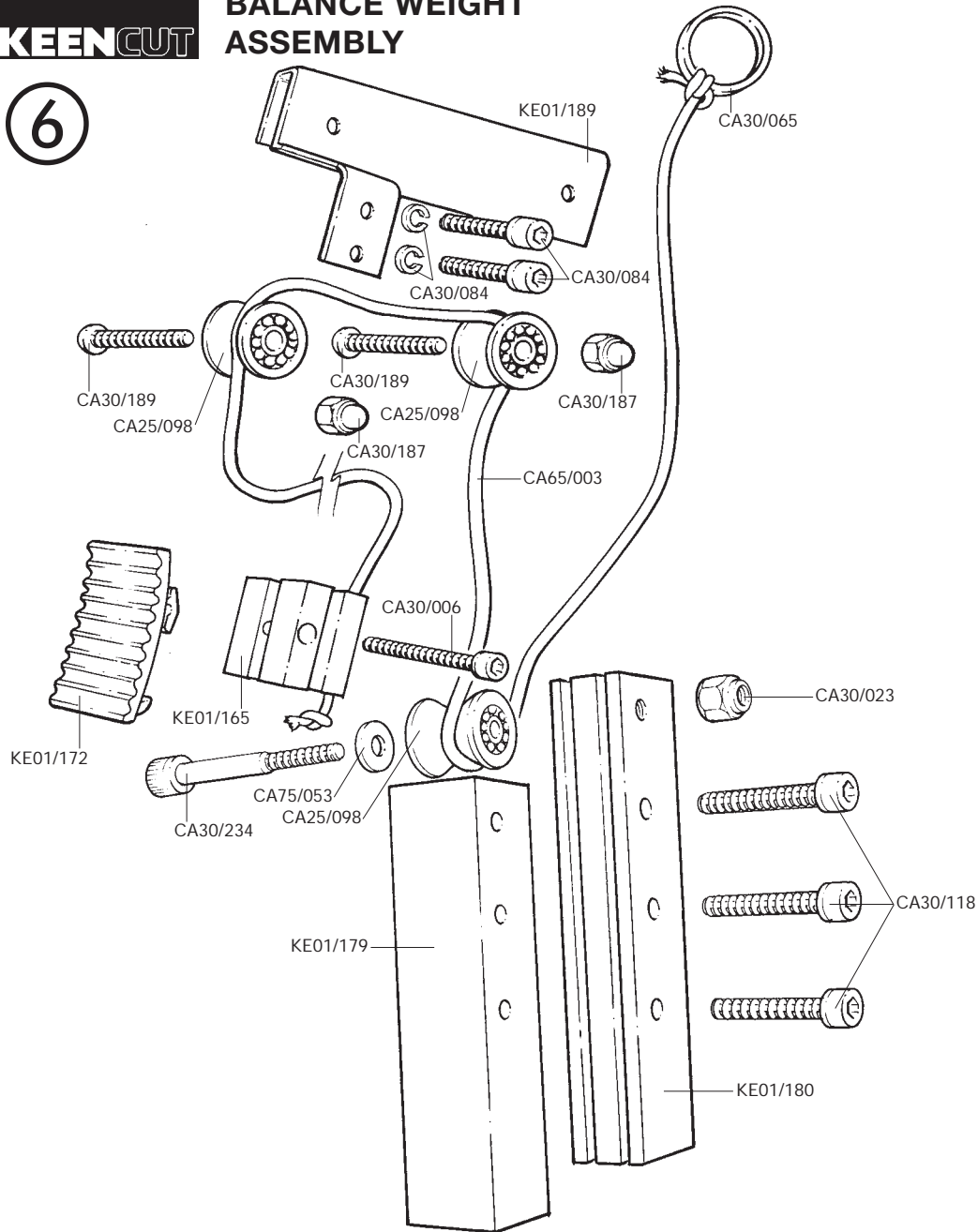

KEENCUT

BOTTOM LEG CLAMP ASSEMBLY

7

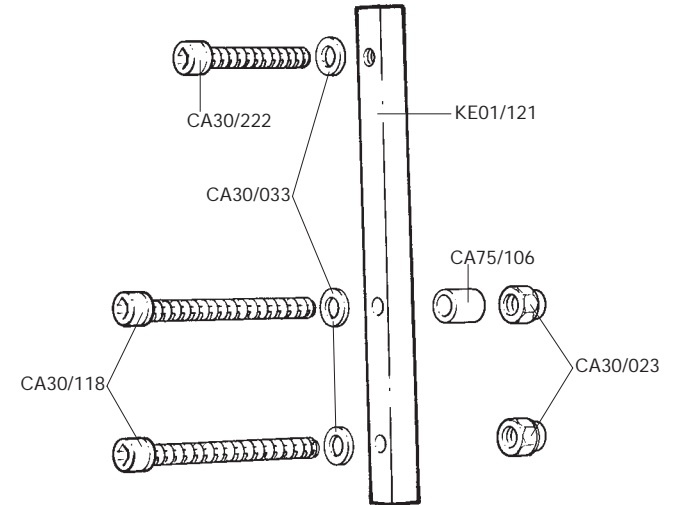

KEENCUT LEFT HAND FLIP STOP

8

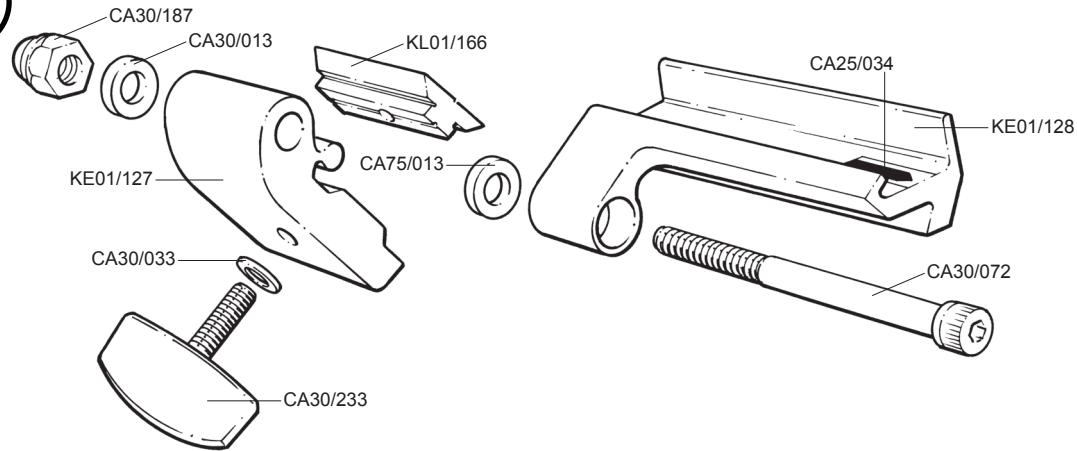

KEENCUT RIGHT HAND FLIP STOP

9

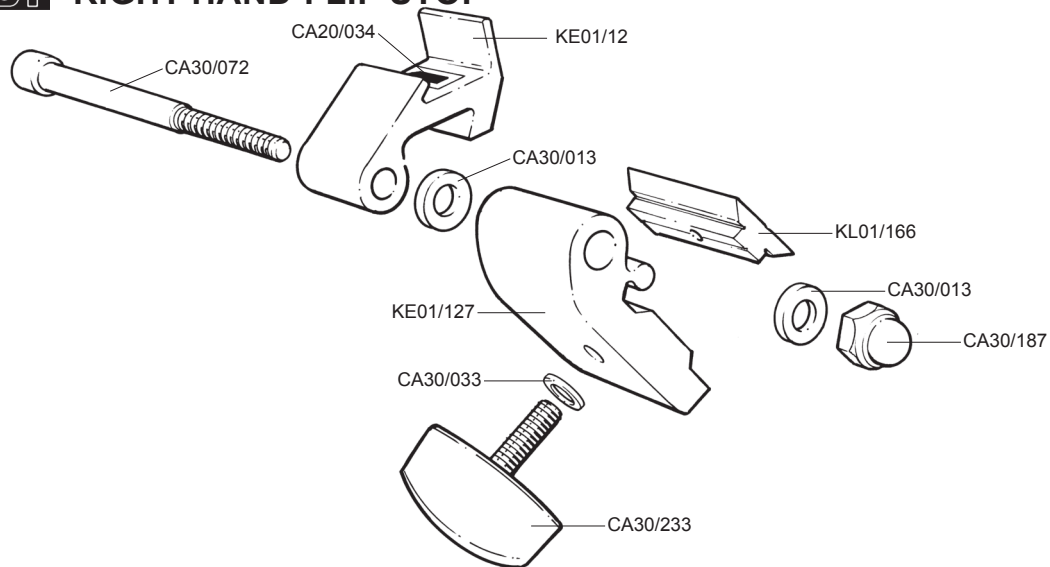

KEENCUT SLIDEWAY ASSEMBLY

10

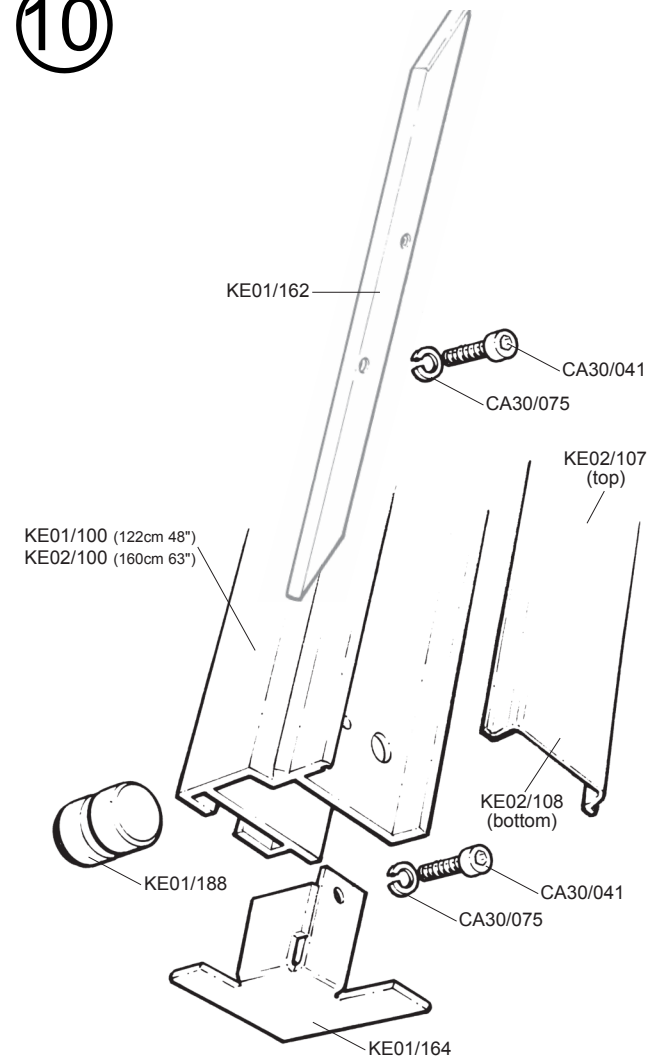

KEENCUT TOP PLATE

11

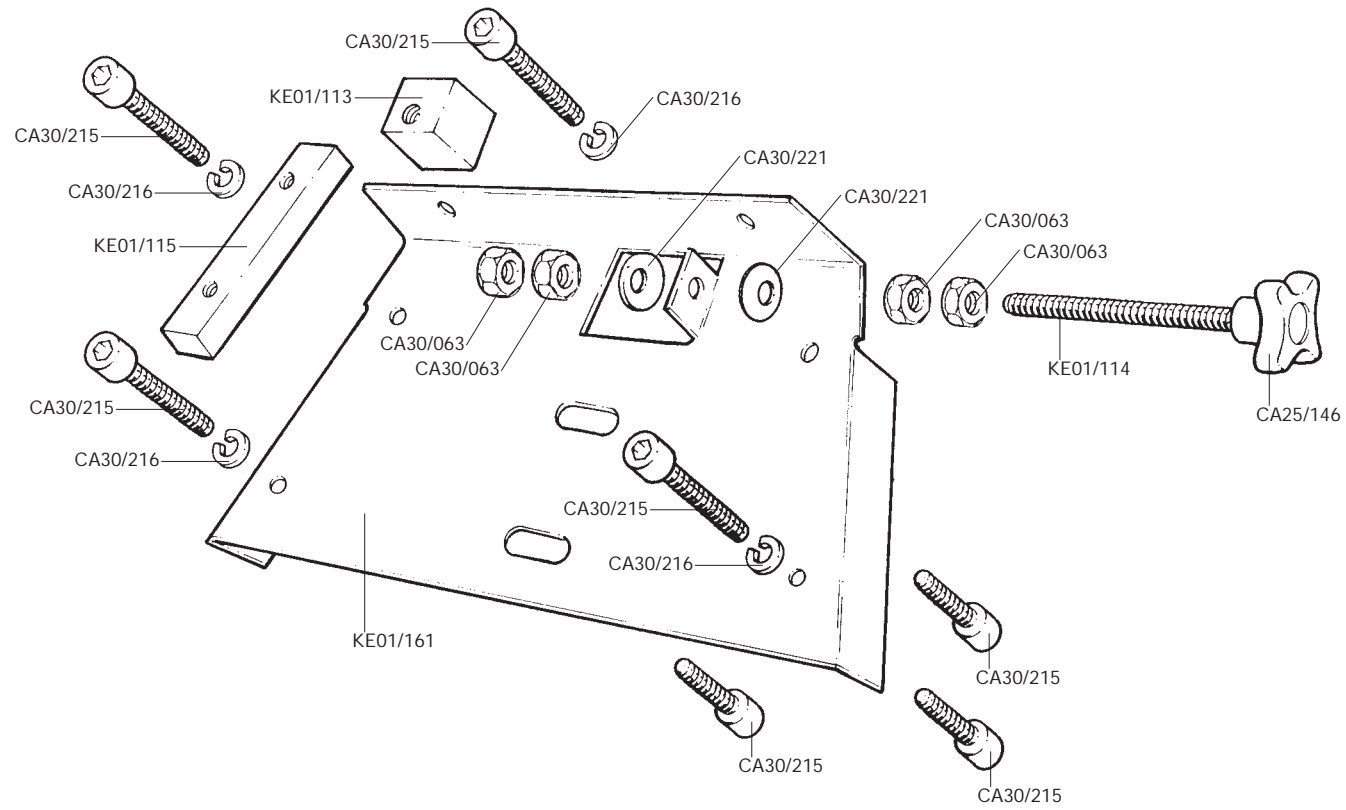

KEENCUT SPINE ASSEMBLY

12

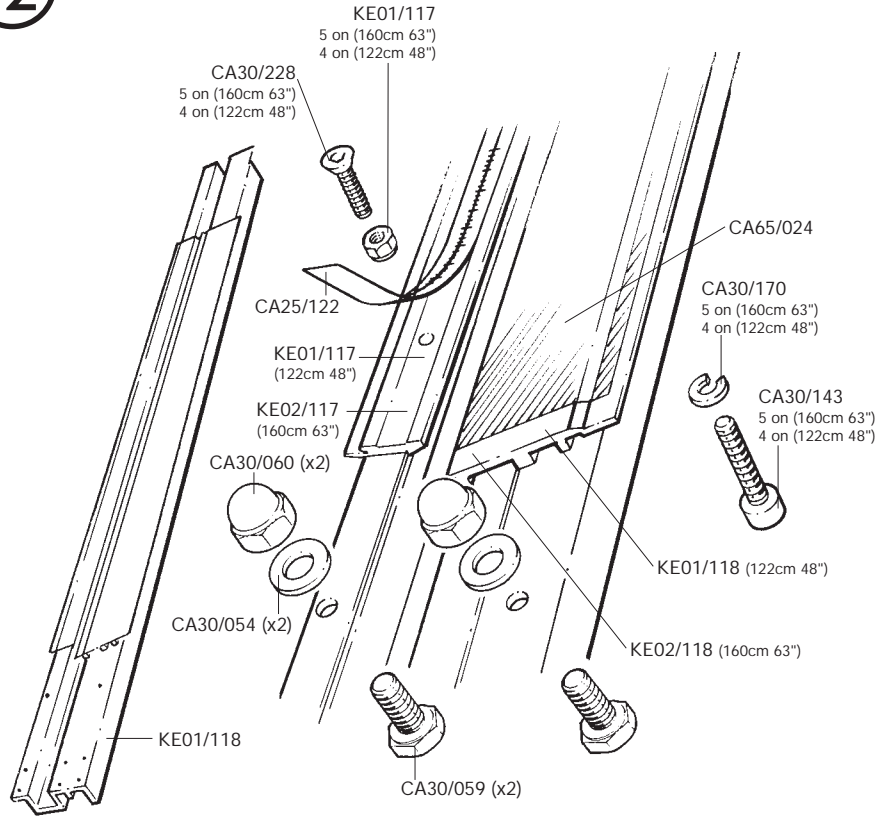

KEENCUT CLAMP PUSH ROD ASSEMBLY

13

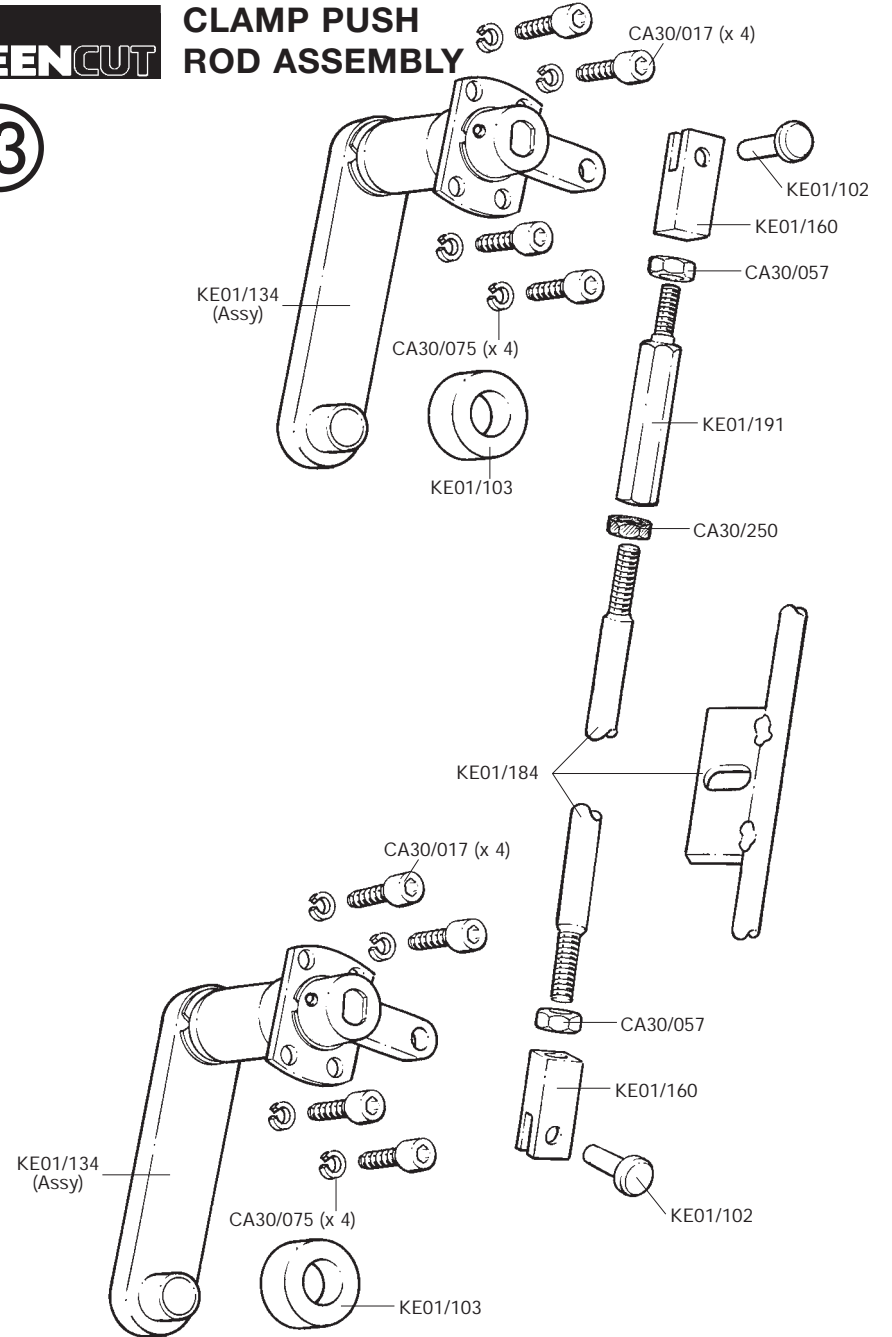

KEENCUT

TOP LEG CLAMP BLOCK

14

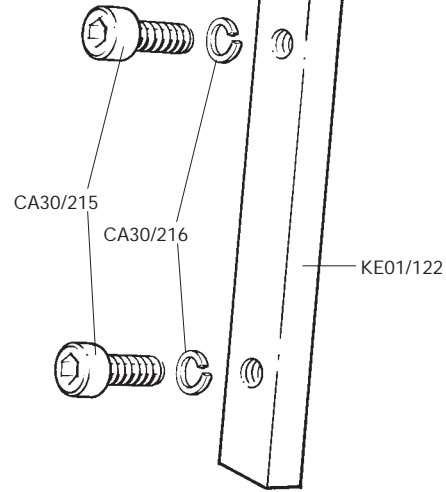

KEENCUT

CLAMP HOUSING ASSEMBLY

15

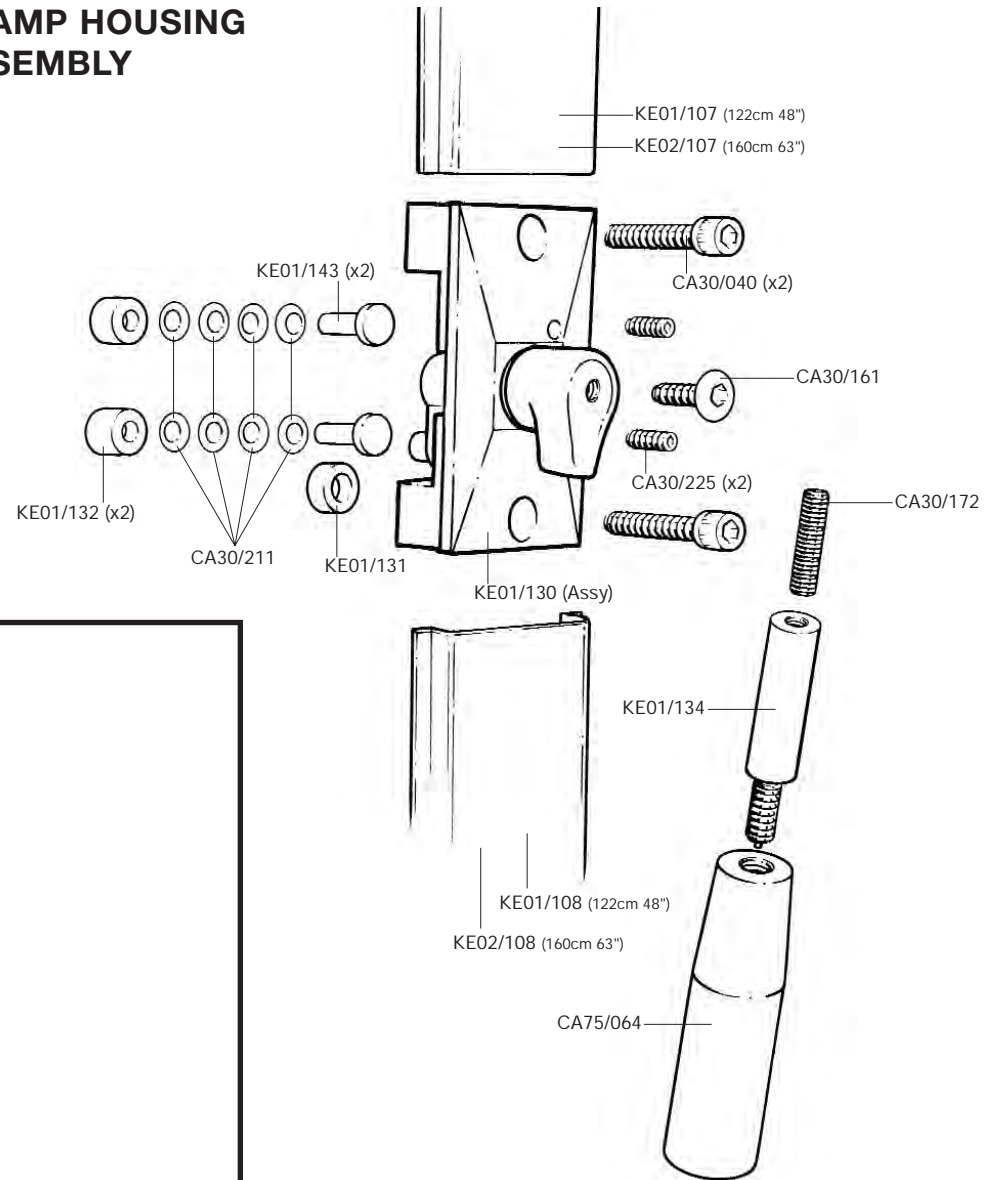

KEENCUT

JOINING BLOCK

16

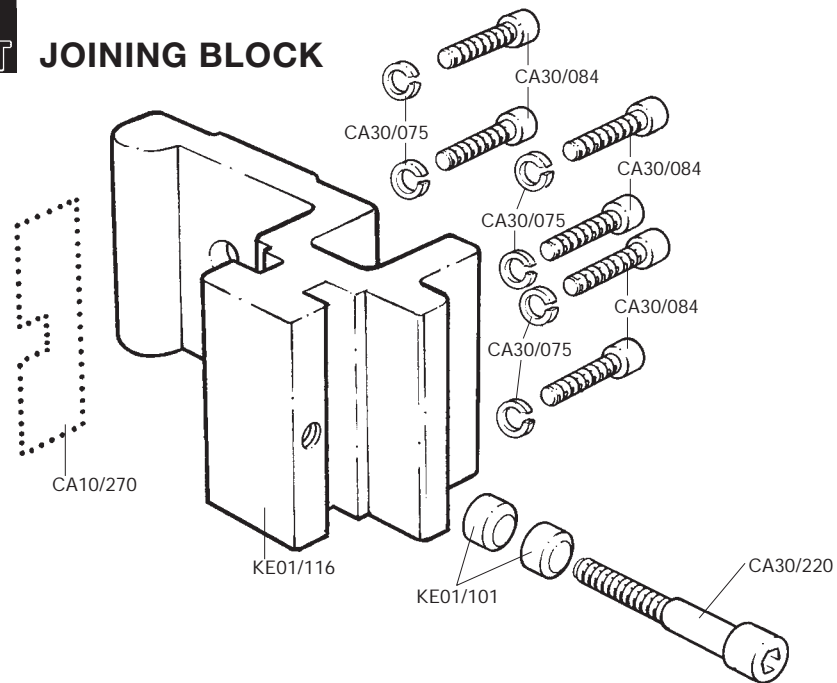

KEENCUT CLAMP BAR

17

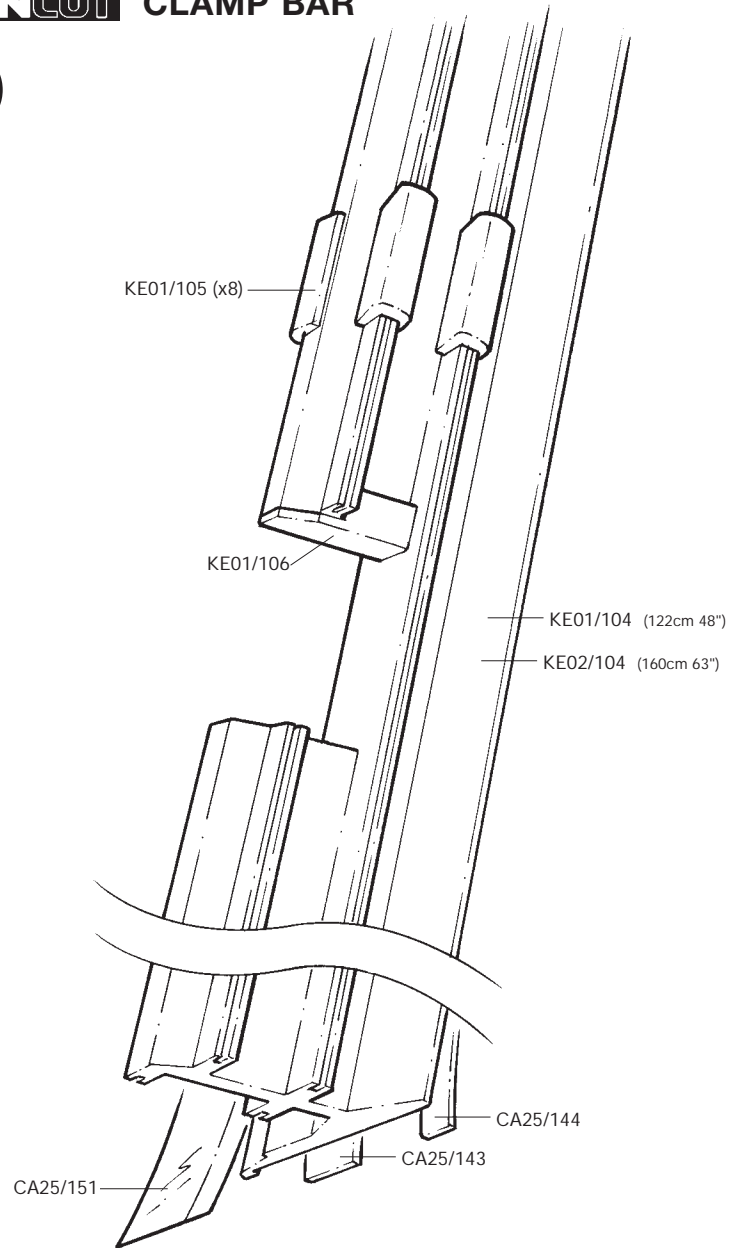

KEENCUT SQUARING ARM

18

