

KEENCUT SYSTEM

INSTRUCTION MANUAL

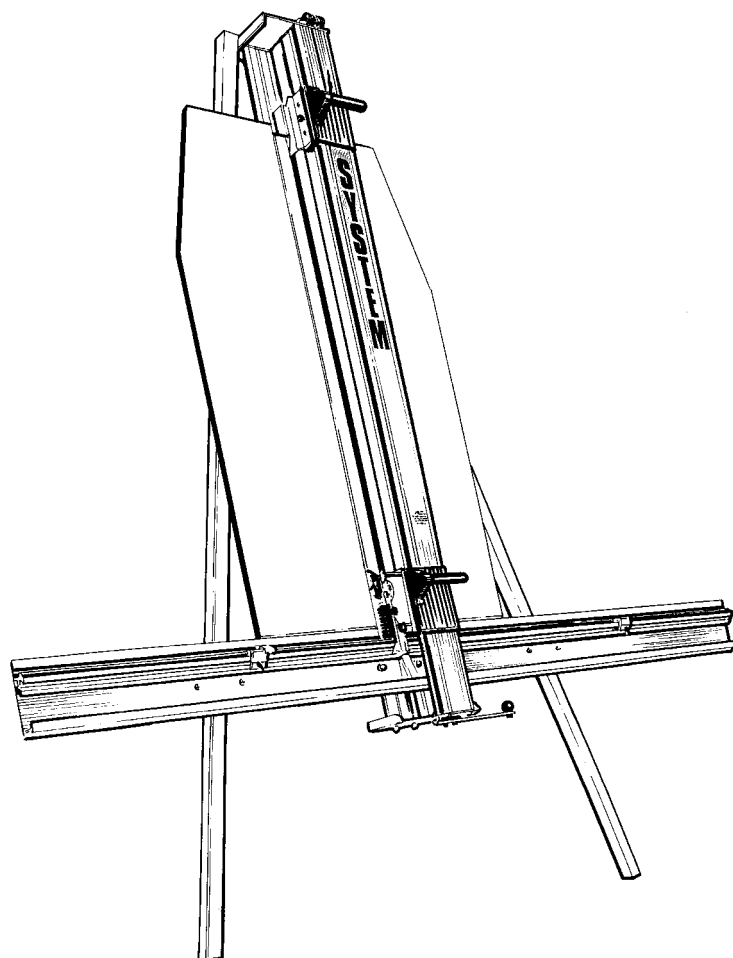

KEENCUT THE WORLD'S FINEST CUTTING MACHINES

2 packing list

- 2 Un-packing your System

3 assembly

- 3 Fitting and adjusting the legs
- 4 Preparing the Squaring arm
- 5 Fitting the Squaring arm
- 6-7 Fitting the Backing boards
- 8 Fitting the Handles
- 9 Fitting the Wall mounting bracket

10 squaring

- 10-12 Squaring your System

13 using your System

- 13 Calibrating the measuring scales
- 14 Selecting the cutting tool
- 15 Cutting Mountboard, Matboard and Foamcore
- 16 Cutting Glass
- 17 Cutting Plexiglass, Acrylic
- 18 Cutting Hardboard/Masonite
- 19 Changing the cutting blades/wheel
- 20 Changing the Hardboard cutting wheel carrier

Maintenance

The System 3000/4000 has been designed to be virtually maintenance free, however we do recommend keeping it clean. Do not wipe the squaring arm channels or any debris with fingers, as it will contain glass particles. Use a vacuum cleaner if possible or if a soft brush is used, work slowly and do not allow particles to flick off the bristles.

The slideway can be cleaned and lubricated occasionally by wiping the bearings with petroleum jelly or silicone applied with a cloth. All excess must be removed with a dry cloth before continuing.

DO NOT USE OIL ON THE SLIDEWAY!

Periodic adjustment of the sliding carriers can be carried out by means of the two screws and locknuts fitted to the right hand side of each carrier. Turning the screws clockwise tightens the bearings.

2 packing list

SYSTEM 4000 / 3000

Un-Packing your SYSTEM

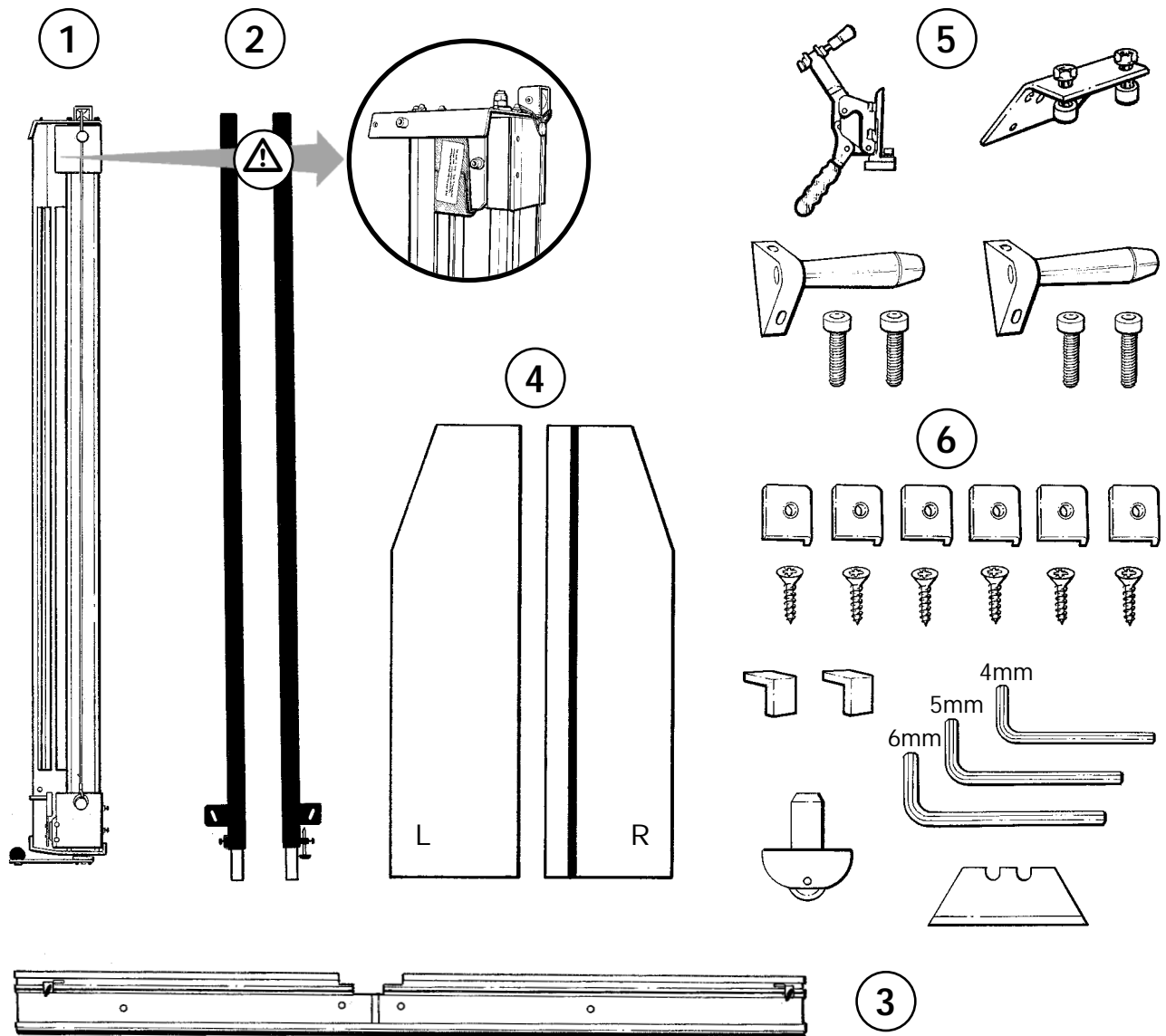

GB English

UN-PACKING YOUR SYSTEM

⚠ DO NOT remove the elastic band or the card packaging around the upper cutting head, until the machine is fully assembled.

- ① Main body (Spine & Slideway)
- ② Legs - Left & Right
- ③ Squaring arm
- ④ Backing boards - Left & Right
- ⑤ Toggle clamp (4000 only), Wall mounting bracket (with nuts and bolts), 2 Handle assemblies, 4 Bolts
- ⑥ 6 Backing board clamps, 6 Countersink screws, 2 Backing board spacers, Allen keys - 4mm, 5mm, 6mm
Spare glass cutting wheel, 50 spare blades

Fitting and adjusting the legs

You will need



SYSTEM 4000 / 3000

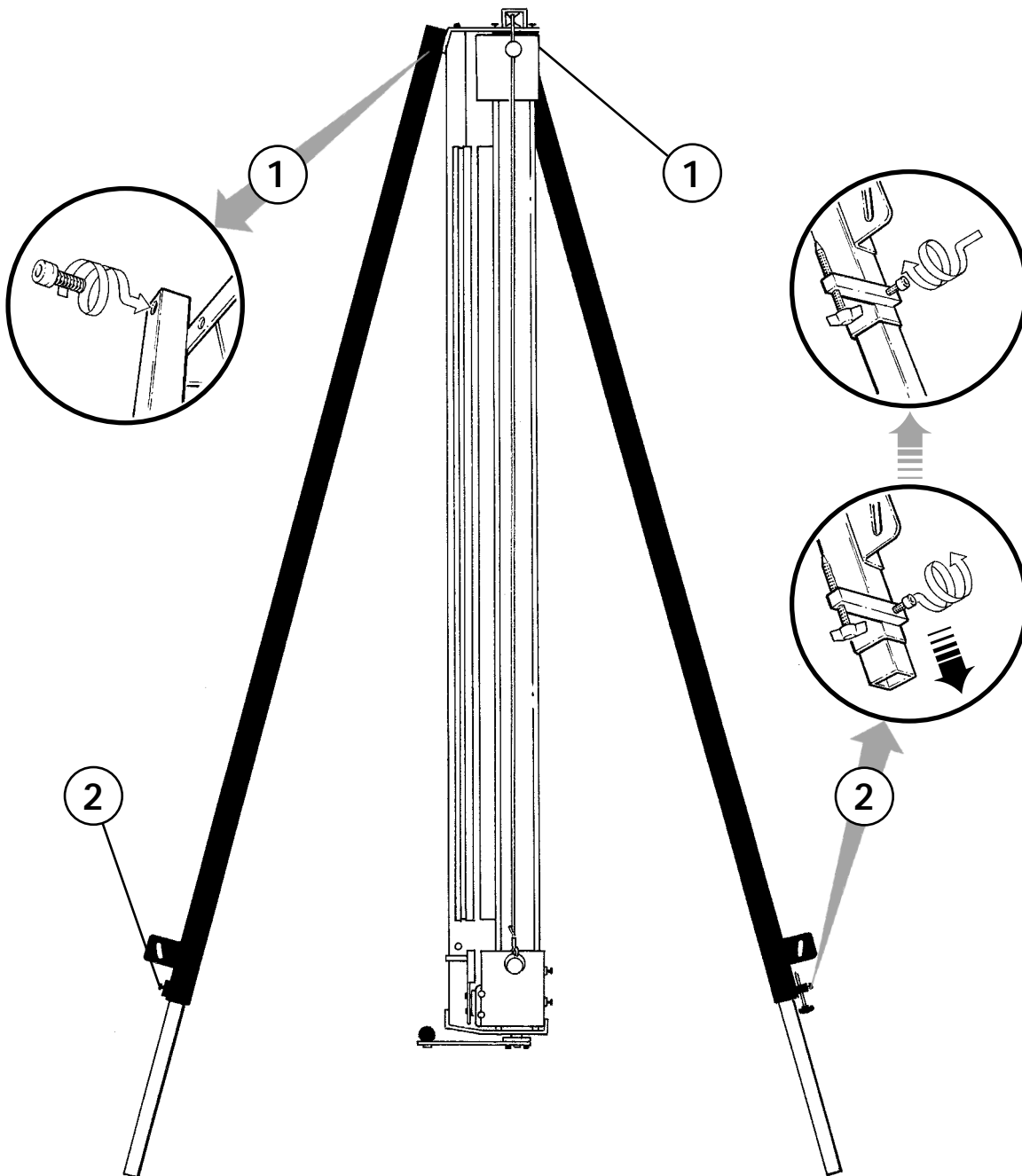

GB English

FITTING THE LEGS

- ① Lay down the Left leg against the top bracket on the Main body. Remove the screw from the bracket using a 6mm Allen key, place the screw through the top of the Leg and screw into the bracket.

Repeat for the Right leg

ADJUSTING THE LEGS

- ② Using a 6mm Allen key loosen the screw on each Leg and slide the (inner) part of each Leg outwards by the same amount to give the desired operating height of your System. Tighten each screw using the 6mm Allen key.

NB: You will now need to retract the Squaring adjustment screw located towards the bottom of the Right hand leg to enable the fitting of the Squaring arm.

4 assembly

Preparing the Squaring arm

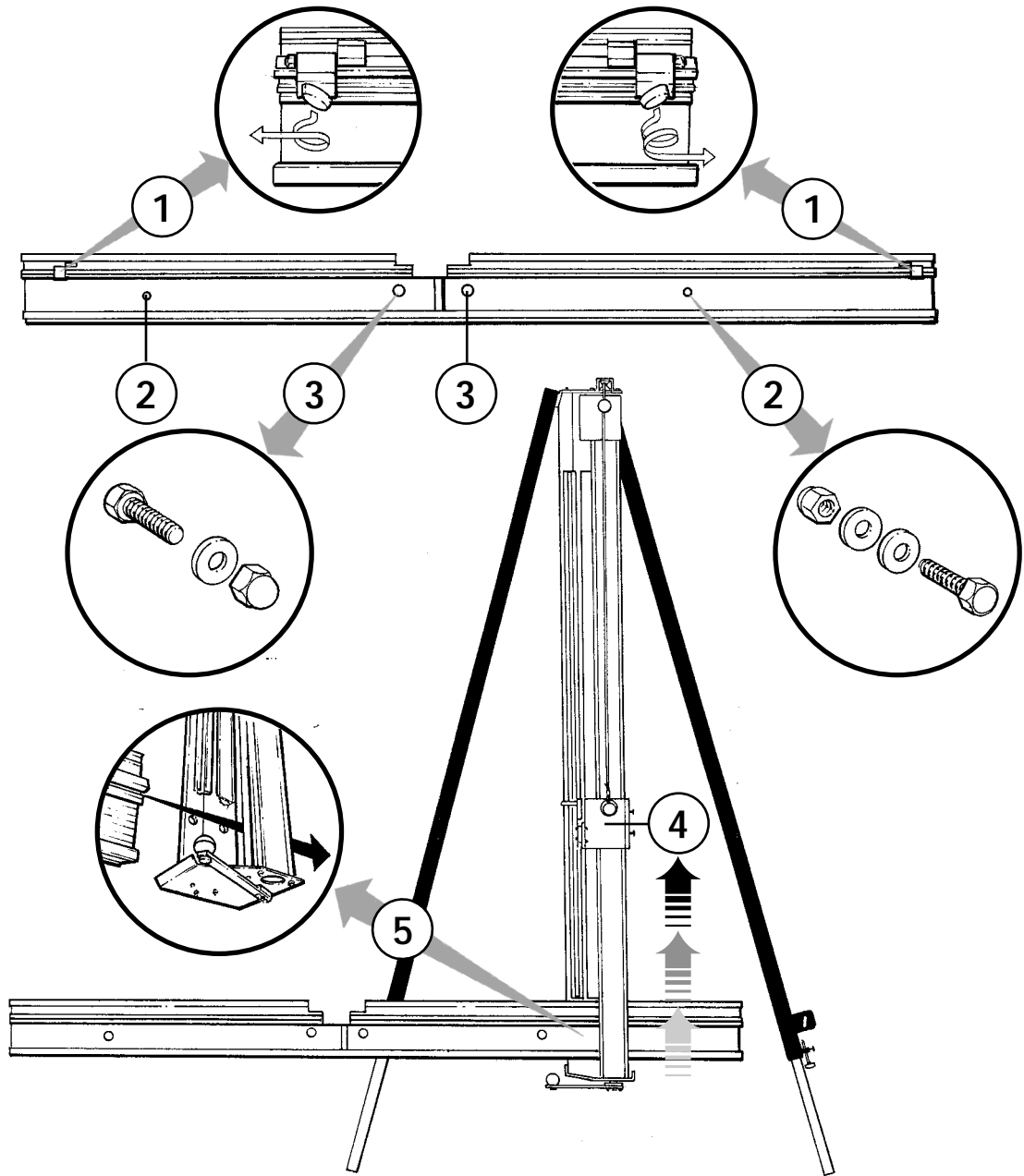

GB English

PREPARING THE SQUARING ARM

- ① Remove the two Flip stops on the Squaring arm by loosening the wing nuts and sliding the Flip stops towards the outside edge.
- ② Remove the two small nuts, bolts and four washers.
- ③ Remove the two large domed nuts, two bolts and two washers.
- ④ Slide the Multi-purpose cutter head upward away from the bottom of the Main body.
- ⑤ Slide the Squaring arm between the Spine and the Slideway at the bottom of the Main body from either side, making sure the two centre holes on the Squaring arm line up with those on the Spine.

Fitting the Squaring arm

You will need

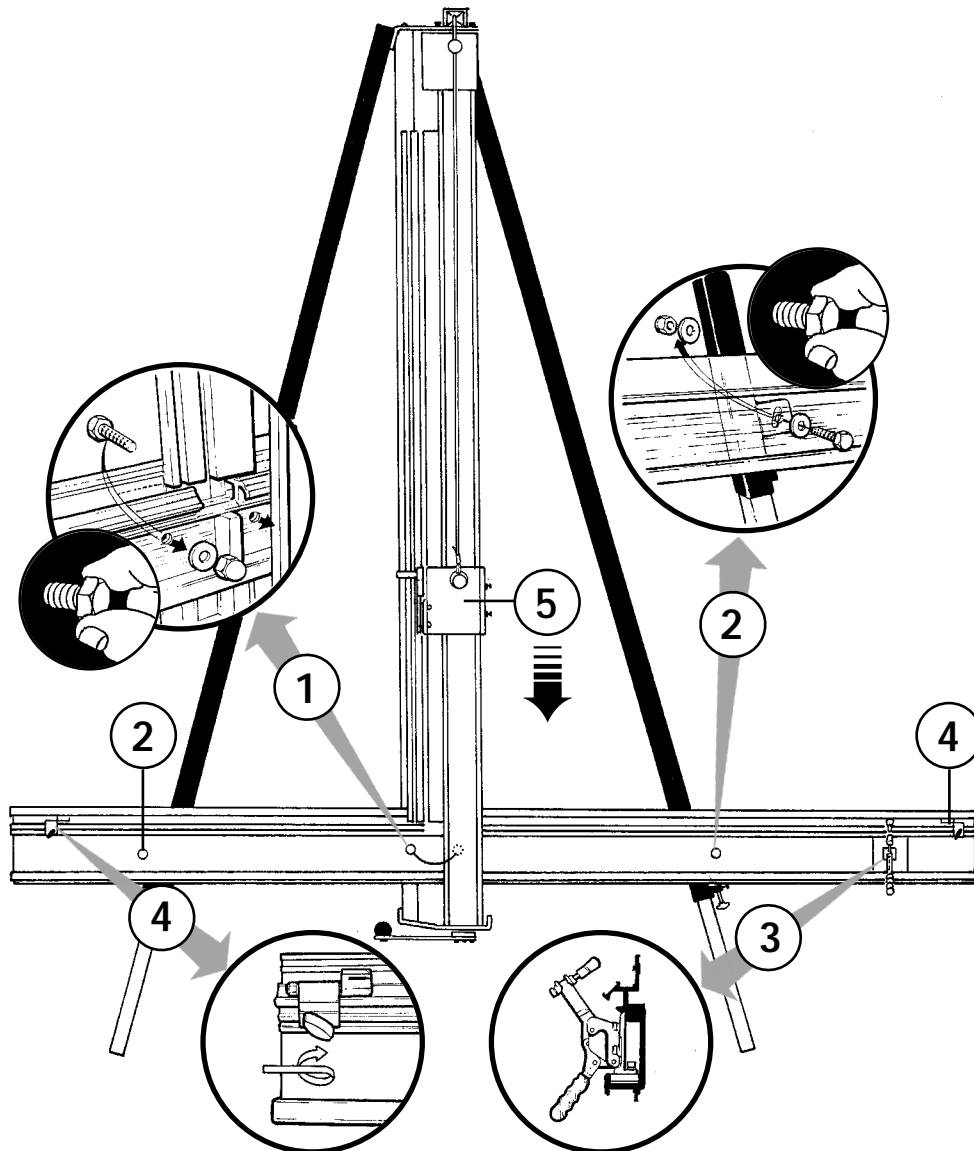
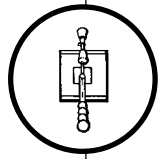

SYSTEM 4000 / 3000

GB English

FITTING THE SQUARING ARM

- ① Insert both of the large bolts from the back through the holes in the Main body, fit the washers and dome nuts *finger tight only*.
- ② Insert a small bolt and washer through both the Squaring arm and the slotted bracket on each Leg, fit a washer and nut *finger tight only*.
- ③ Attach the Toggle clamp (4000 only) to the Squaring arm by sliding it in from the right hand edge.
- ④ Slide in the Right hand Flip stop onto the scales from the right, and the Left hand Flip stop onto the scales from the left side of the Squaring arm.
- ⑤ Slide the Multi-purpose cutter head back to its resting position at the bottom of the Main body.

6 assembly

You will need

Fitting the Backing boards

SYSTEM 4000 / 3000

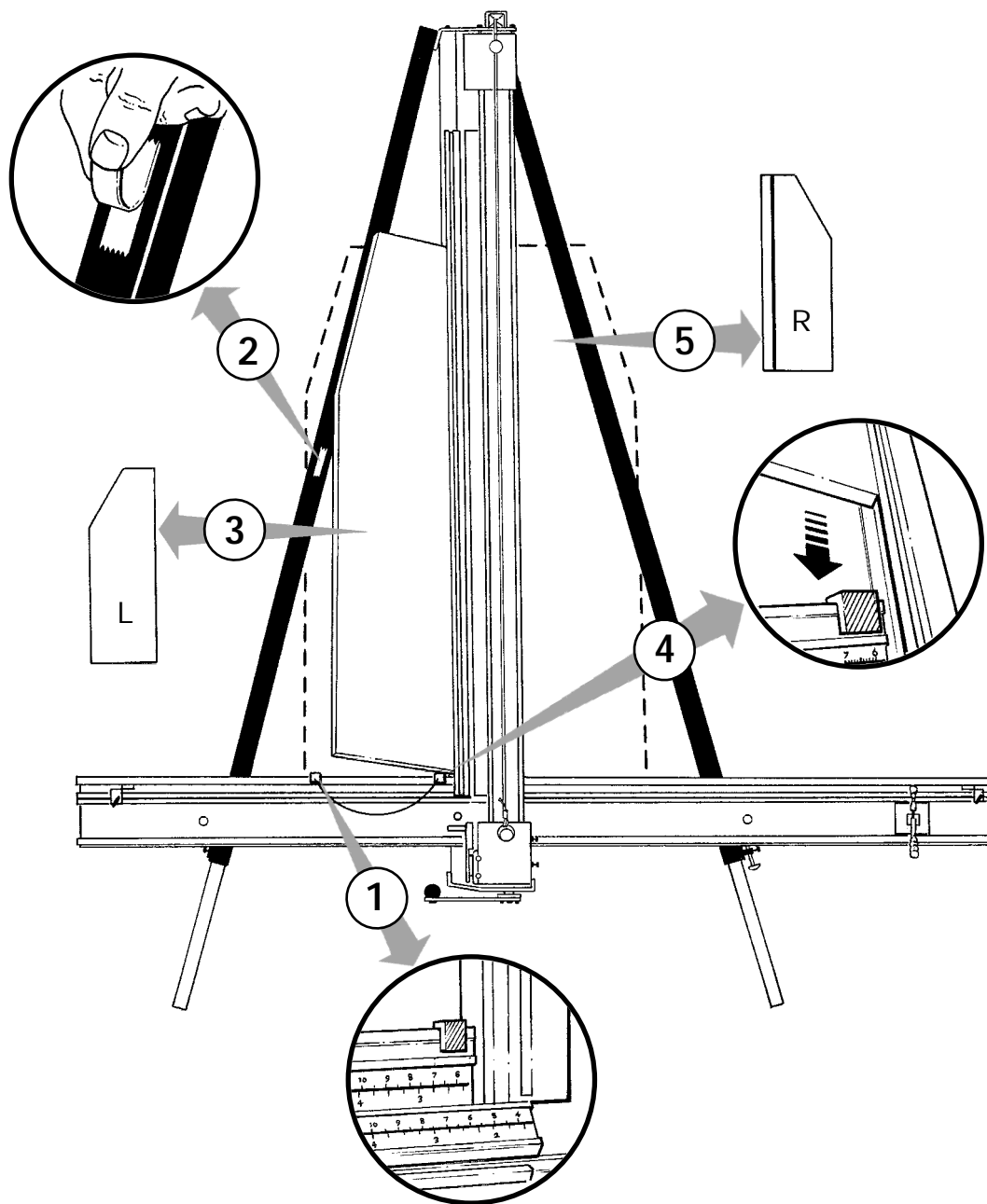
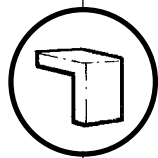

GB English

FITTING THE BACKING BOARDS

NB: The backing boards are Left and Right handed, the Right board is identified by the Black Foam Strip which runs from top to bottom.

- ① Place the 'L' shaped spacers on the top edge of the Squaring arm.
- ② Remove the release paper from the double sided tape on the Left leg.
- ③ Offer the long edge of the Left Backing board to the Spine on the Main body (making sure the Backing board does not touch the Leg).
- ④ Slide the Backing board down the Spine towards the spacers on the Squaring arm and when touching allow to drop down onto the Leg.
- ⑤ Remove spacers.
- ⑥ Repeat for Right leg.

NB: The spacers can now be discarded.

Fitting the Backing boards

You will need

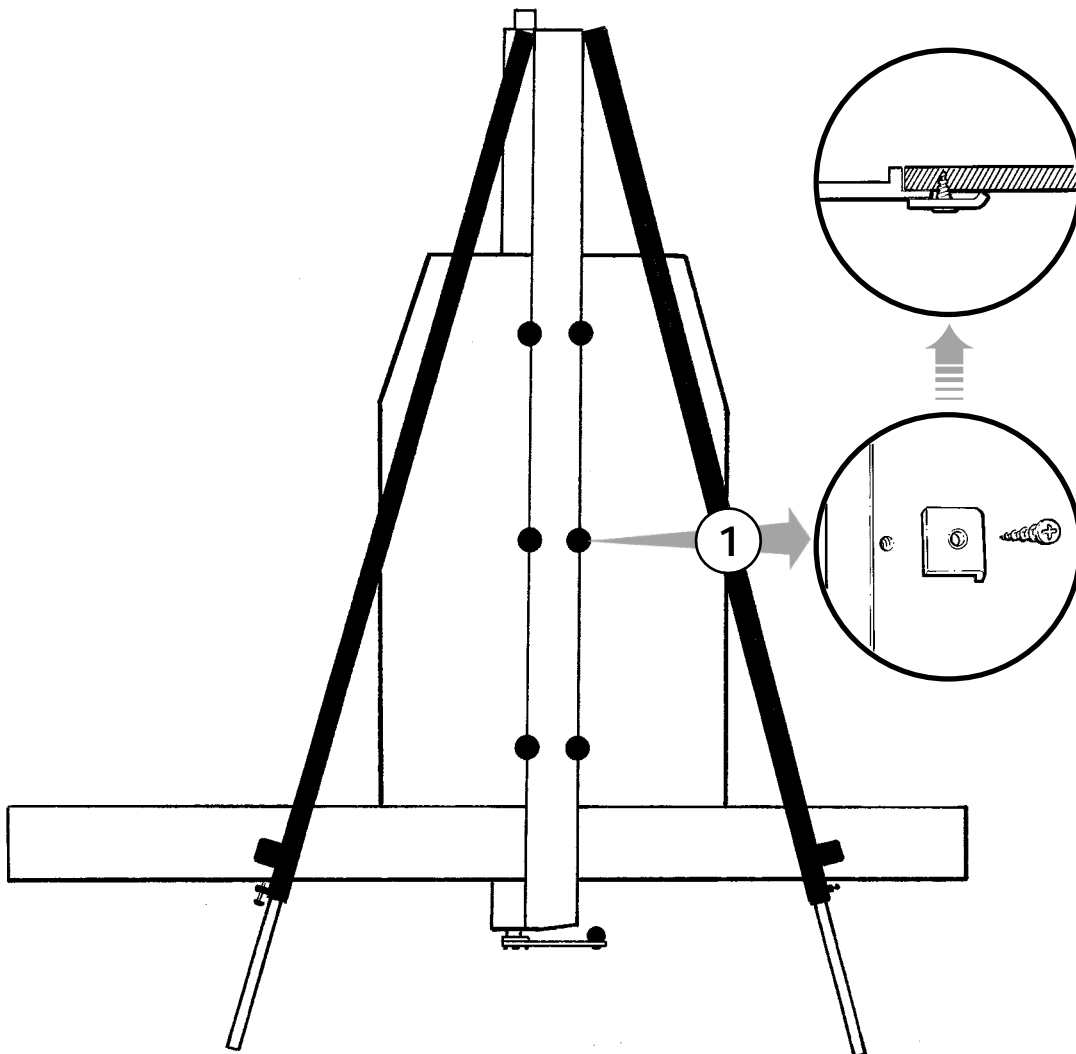
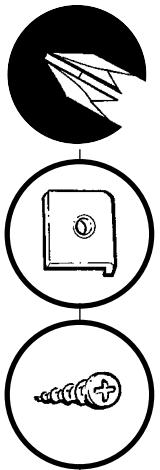

SYSTEM 4000 / 3000

GB English

FITTING THE BACKING BOARDS

NB; You will now need to stand the System upright and support it to allow access to the rear of the machine.

- ① Locate the six pilot holes in the rear of the Backing boards and fix to the Spine using the six clamps and Self tapping screws provided.

NB; Do not over-tighten the screws or damage could occur to the Backing boards.

You will need



5mm

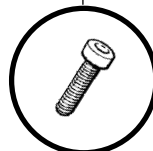
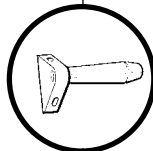

SYSTEM 4000 / 3000

Fitting the Handles

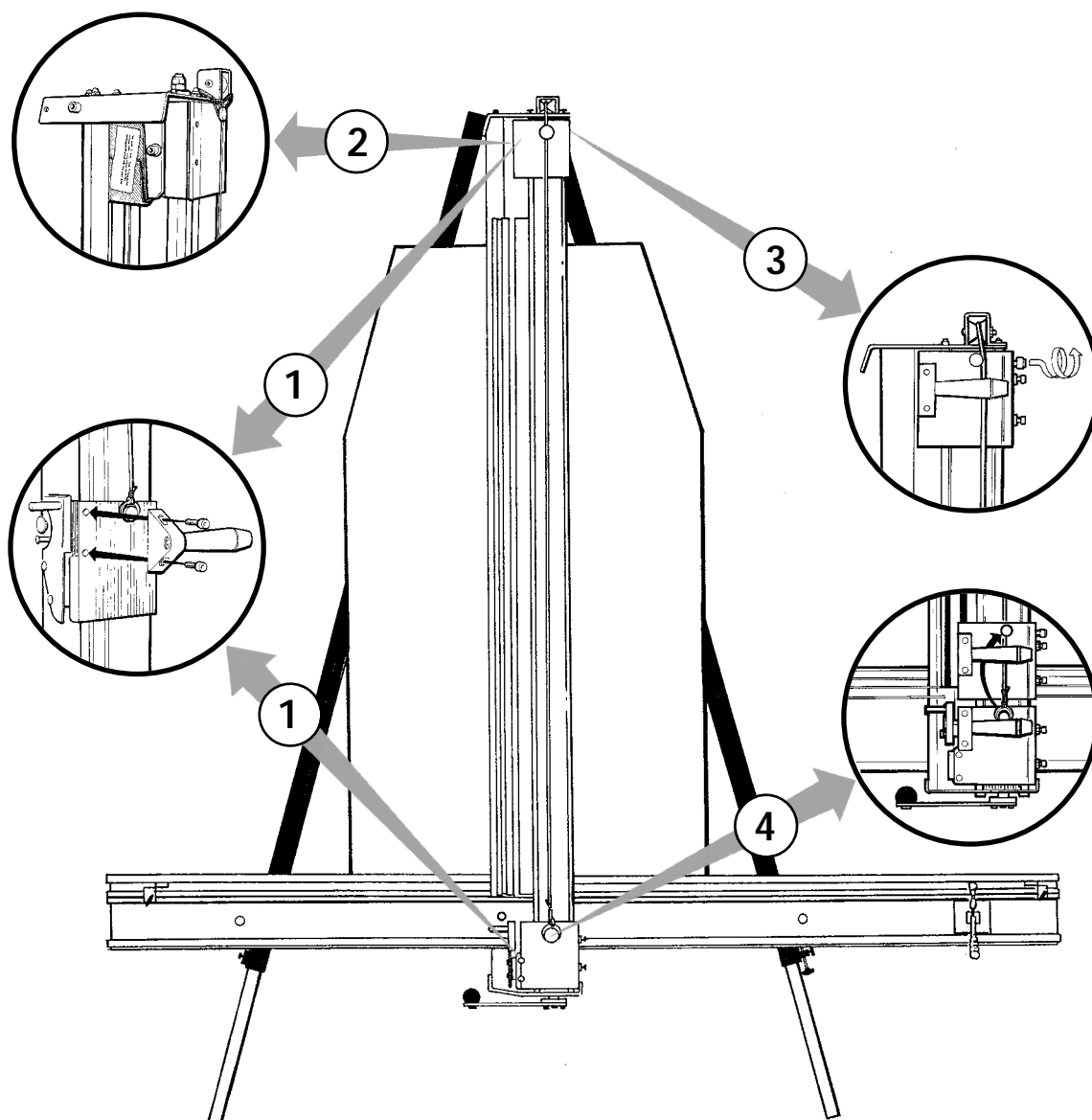

GB English

FITTING THE HANDLES TO BOTH SLIDING HEADS

- ① With the hand grip to the right of the Handle bracket align the two fixing holes on each Handle with those in each Head. Fit the bolts and tighten with the 5mm Allen key provided.
- ② Making sure the Counterbalance Fixing Ring is still attached to the Lower cutting head, remove both the card packaging and the elastic band from the cutter.
- ③ Loosen the white plastic screw on the right side of the Upper cutting head and move to the bottom of the Main body.
- ④ Remove the Counterbalance Fixing Ring from the Lower cutting head and attach to the Upper cutting head which can now be parked at the top of the Main body.

Fitting the Wall mounting bracket

You will need

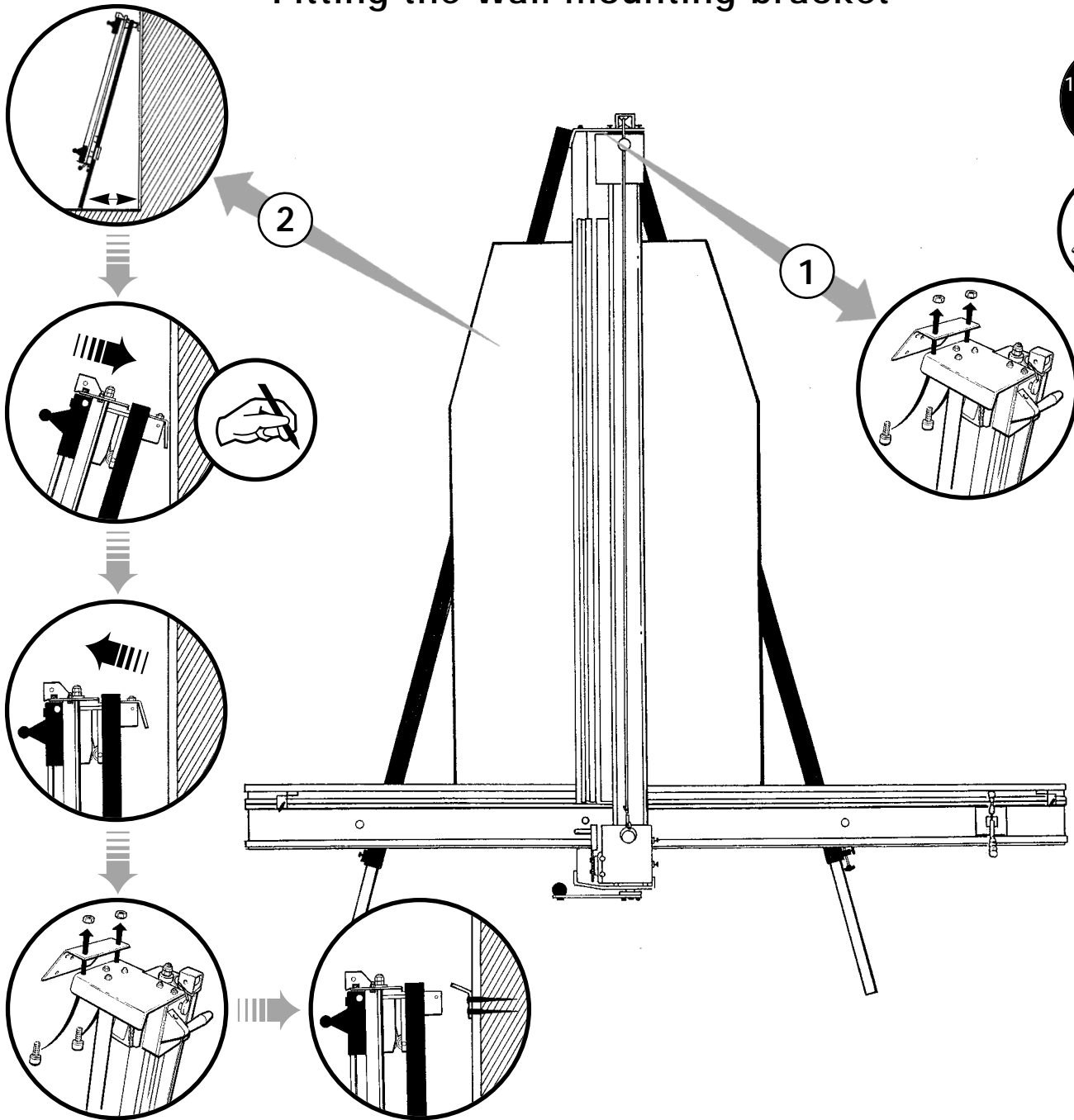
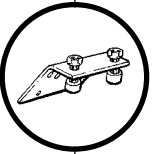

SYSTEM 4000 / 3000

GB English

FITTING THE WALL MOUNTING BRACKET

NB: When fixing the System to a wall make sure the wall is stable and use the appropriate wall fixings.

- ① Attach the Wall mounting bracket to the top of the Main body using the nuts and bolts provided. (This operation can also be carried out with the System lying flat on the floor).
- ② With the legs positioned about 35cm (14") away from the wall, gently lean the top of the System against the Wall. Use the position of the Wall mounting bracket against the wall to mark the position of the wall fixings. Move the System away from the wall, remove the Wall mounting bracket and fix the bracket to the wall. Offer the System to the Wall mounting bracket and attach to the main body of the System.

THE SYSTEM IS NOW READY FOR SQUARING

10 squaring

You will need

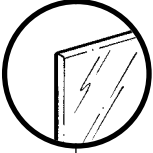

SYSTEM 4000 / 3000

Squaring your SYSTEM

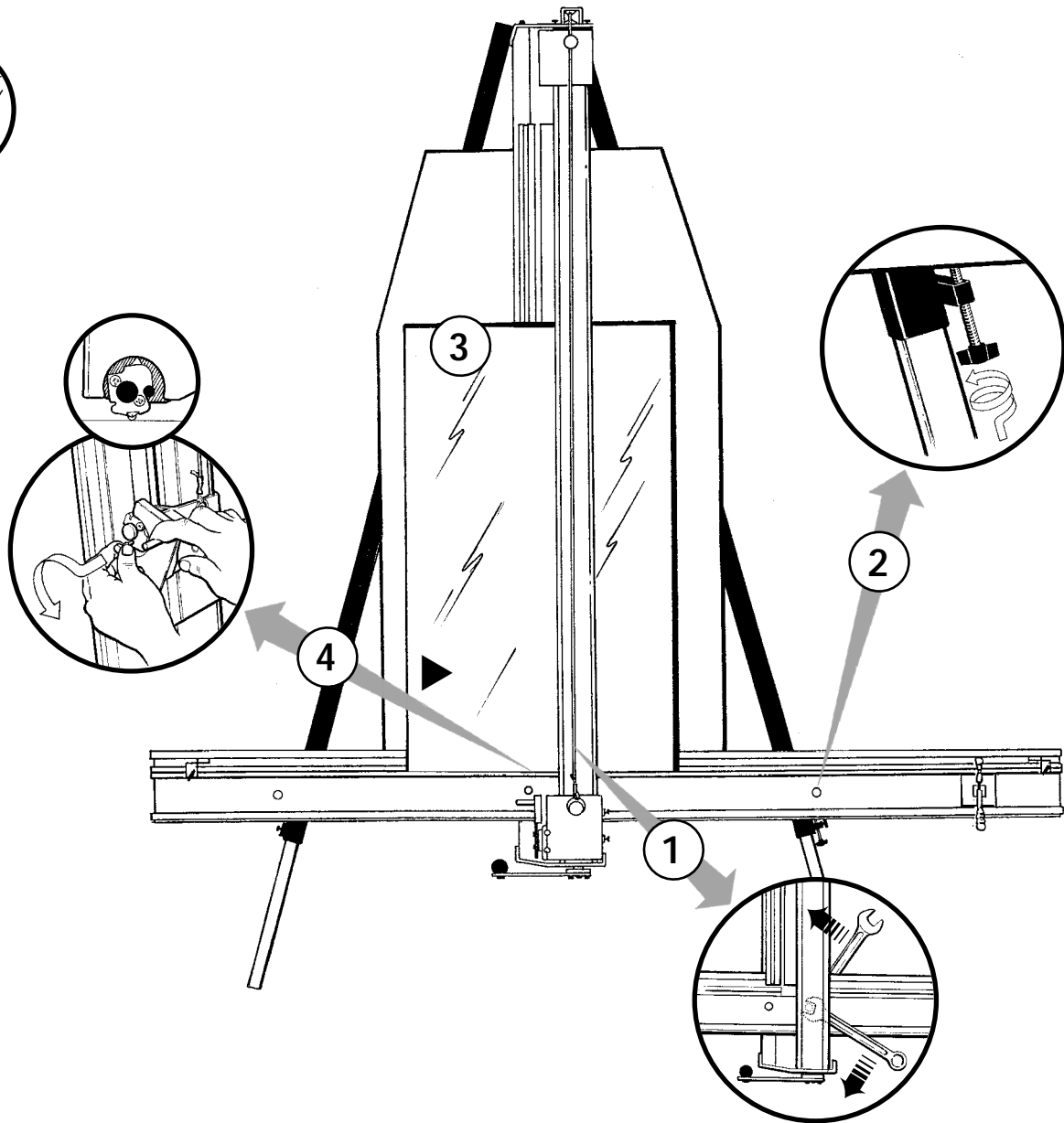

GB English

SQUARING YOUR SYSTEM

- ① Using two 17mm spanners/wrench tighten up the large bolt located directly beneath the Slideway. Ensure the other three bolts on the Squaring arm are loose.
- ② Rotate the adjustable screw on the right hand Leg until it touches the Squaring arm
- ③ Place the sheet of glass vertically on the machine.
- ④ Select the Glass cutting wheel by pulling out the small locking pin and rotating the turret.

NOW REFER TO GLASS CUTTING

Squaring your SYSTEM

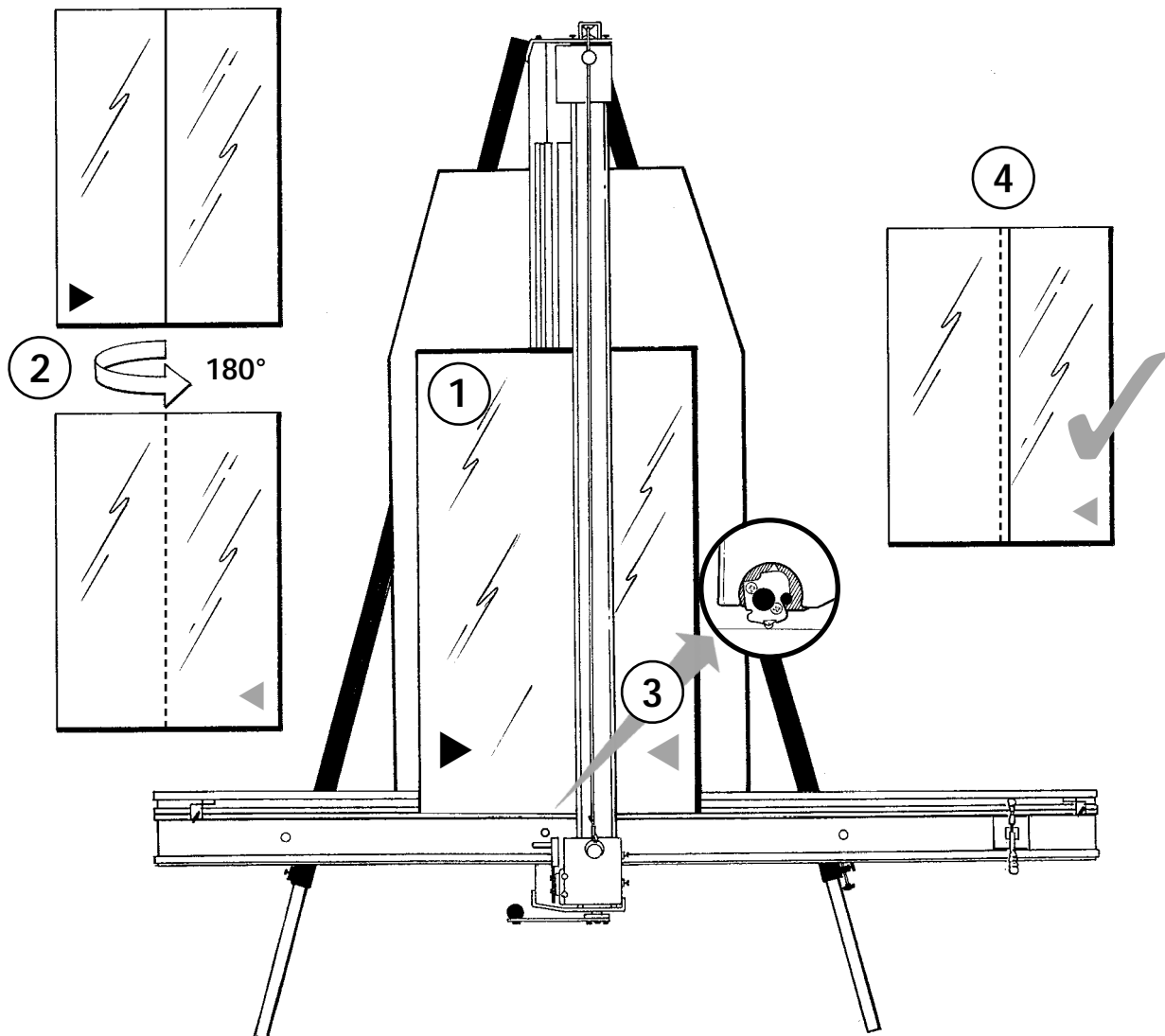

SYSTEM 4000 / 3000

GB English

SQUARING YOUR SYSTEM

- ① Score a line down the centre of the glass but DO NOT break it.
- ② Carefully remove the glass and rotate it (as you would turn the page of a book), so the score line now appears on the back of the glass and the same edge is still on the Squaring arm.
- ③ Place the glass back on the System and align the glass cutting wheel with the bottom of the score line.
- ④ Now score the glass. If the machine is square both score lines will be parallel.

12 squaring

You will need



Squaring your SYSTEM

SYSTEM 4000 / 3000

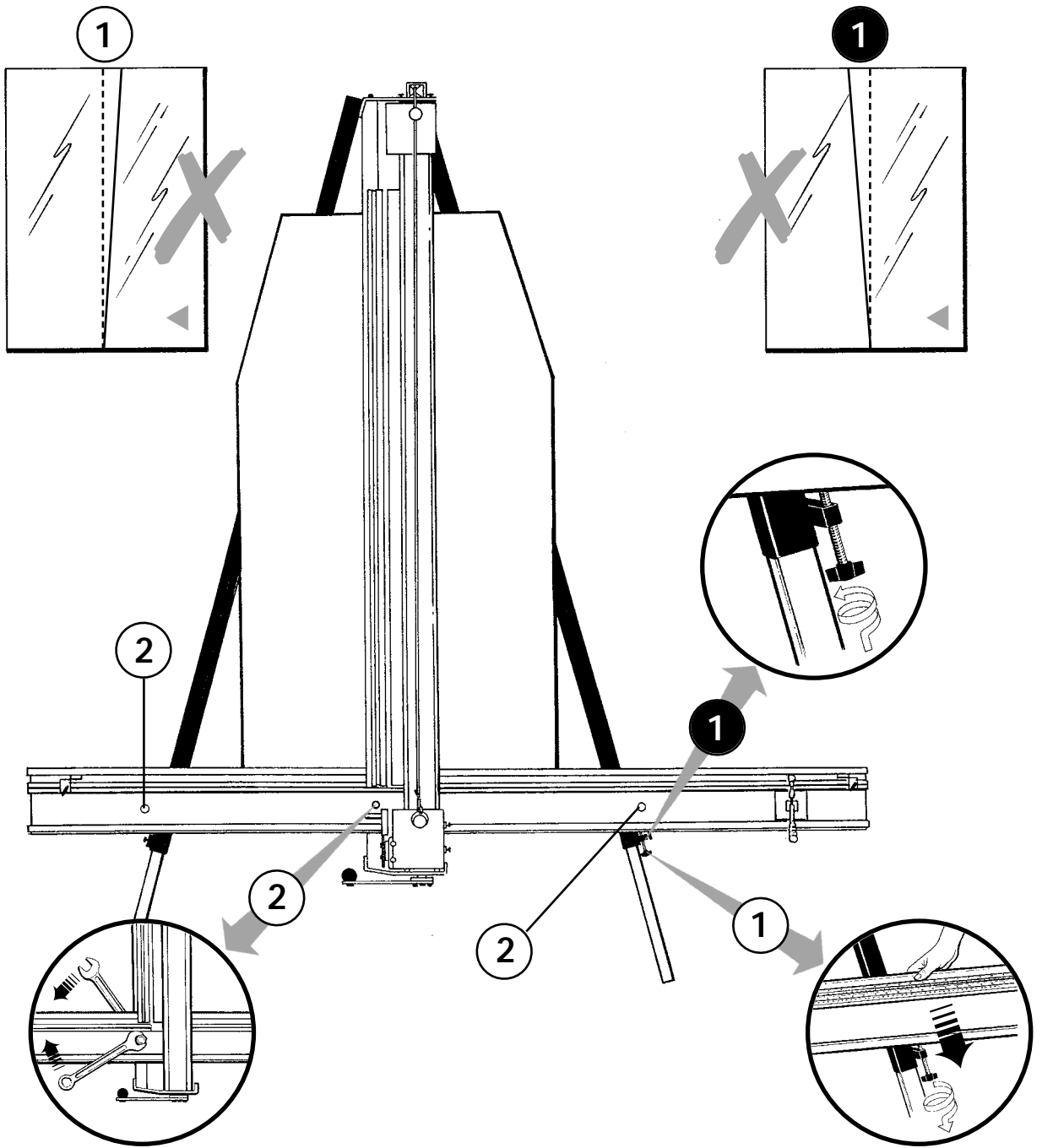

GB English

SQUARING YOUR SYSTEM

LOOKING AT THE TOP OF THE GLASS

- ① If the last score line has cut to the right of the score on the reverse, the right end of the Squaring arm has to be lowered.
- ❶ If the last score line has cut to the left of the score on the reverse, the adjustment screw on the right hand leg will need to be tightened to raise the right end of the Squaring arm.

Repeat ① or ❶ until both score lines are parallel

- ② Now tighten the two nuts and bolts attaching the left and right Legs to the Squaring arm and then tighten the remaining large dome nut and bolt to the left of the Slideway.

Calibrating the measuring scales

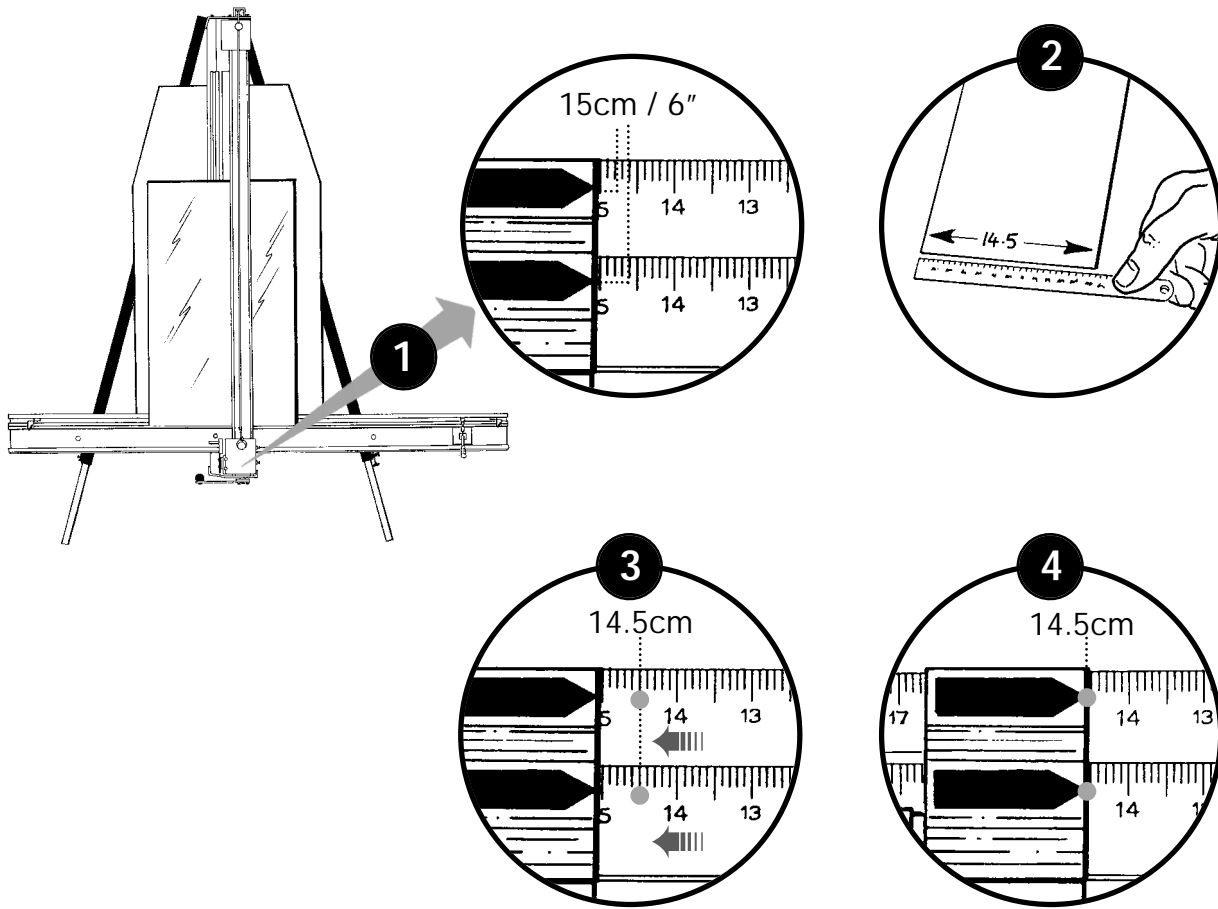

GB English

CALIBRATING THE MEASURING SCALES

The production stops and scales eliminate the need to mark the material to be cut and provide accurate repeat cutting. The vertical scale is for setting a sheet of material on the machine by eye if it is desirable to leave the stops undisturbed. Both stops can be set on only one side of the squaring arm if desired and extra stops are available.

- 1 Set the left hand measuring stops to any setting, say 15cm or 6". Flip the right hand stop to the open position and place a sheet of card onto the right hand squaring arm. Slide the material from right to left until it contacts the left hand measuring stop and clamp it.
- 2 Cut the material, remove the piece from the machine and using an accurate rule measure the exact distance from the edge which was against the stop to the cut line.
- 3 If the scales are accurate the readings will be the same as the measurement of the cut piece if not adjust as follows. Let us assume that the cut as measured is actually 14.5cm not the 15cm that was set on the stop.
- 4 Do not move the stop. Slide both scales until the measurement 14.5 is indicated at the stop and the scale is then set.

If the scales move too freely it is simple to increase the friction. To avoid resetting the scales first choose any easily remembered dimension and set the stop. Slide the scale from its groove, twist it and replace it to the remembered dimension.

Check and correct the right hand stop in the same way but moving the material from left to right.

Selecting the cutting tool

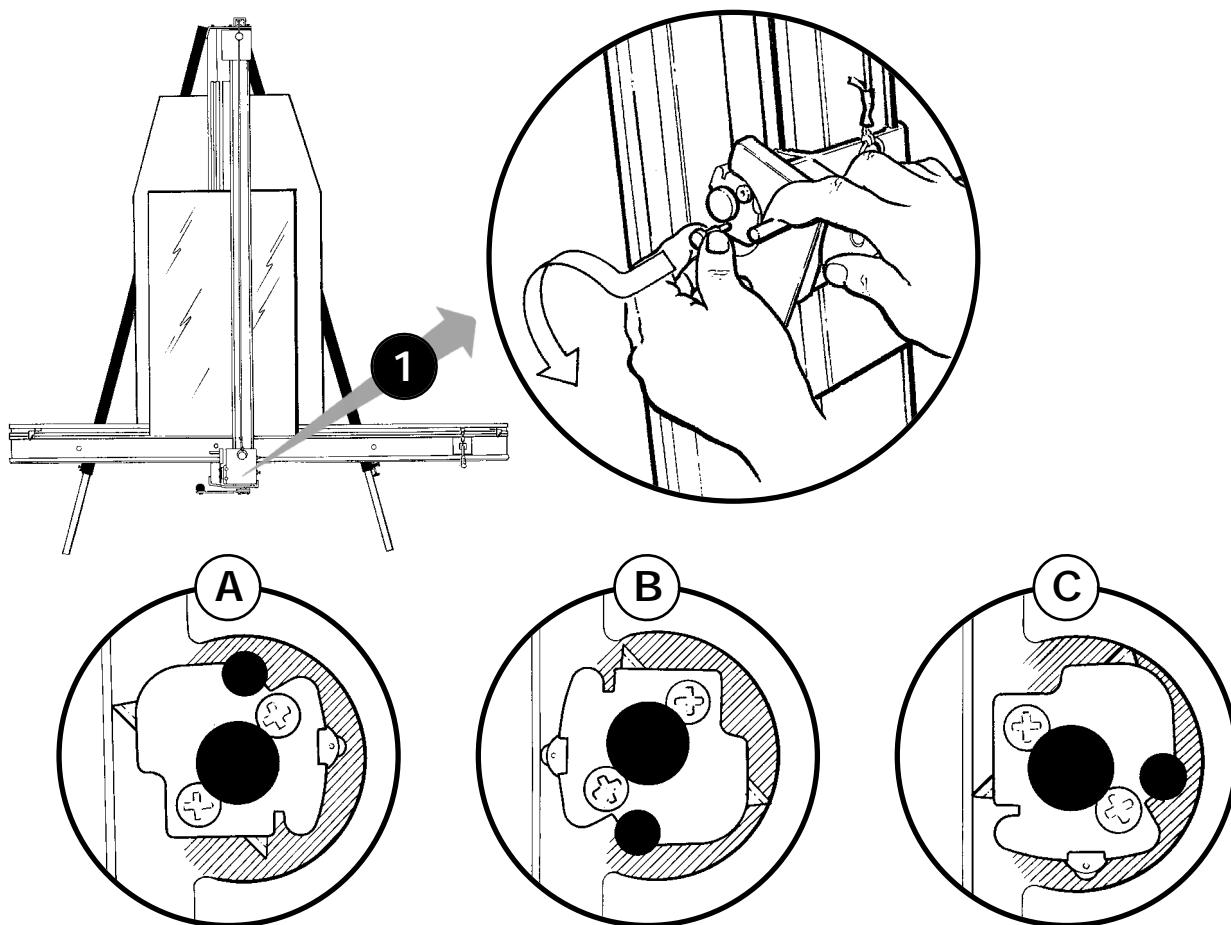

GB English

SELECTING THE APPROPRIATE CUTTING TOOL

As you will have noticed, the System 4000 is equipped with two separate sliding carriers. The upper carrier is fitted with a twin rotary wheel head for cutting hardboard, masonite, matboard and heavy duty card. The lower carrier is fitted with a spring loaded three position turret – refer to diagram 1 above and text below to select the required cutting tool in turn, A the Glass cutter wheel, B the Utility knife blade for matboard, foamcore and other semi-rigid materials and lastly C the reverse end of the Utility knife blade for the very effective scoring of Plexiglass and other acrylics or rigid plastics.

- 1 The different cutting tools are selected by pulling the small turret lock pin to allow the turret to rotate and if the pin is released it will automatically engage in the next position.

NB: Please refer to page 18 for cutting Hardboard.

Cutting Mountboard, Matboard and Foamcore

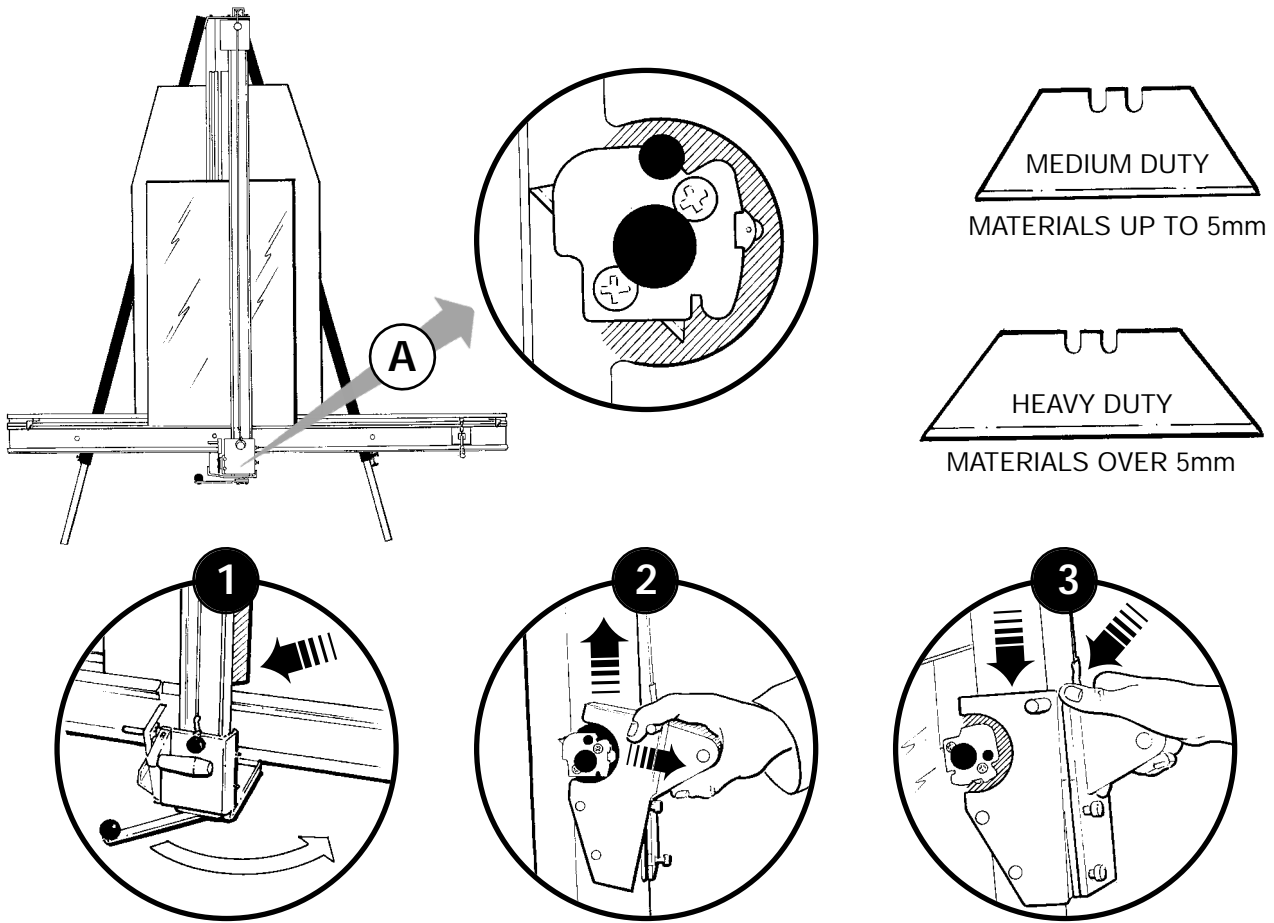

GB English

CUTTING MOUNTBOARD, MATBOARD AND FOAMCORE

Select the Utility Knife **A** by rotating the turret. For material thicker than 5mm change the medium duty blade for a heavy duty Utility blade which is longer.

- 1** Set the measuring stops and hold the board in place using the long vertical clamp.
- 2** Pull back the turret with the steel handle provided and move the carrier up in readiness to cut.
- 3** Release the steel handle and place the thumb of the right hand on top of the turret cover. Push the blade firmly through the material from top to bottom and park the head.

SYSTEM 4000 / 3000

Cutting Glass

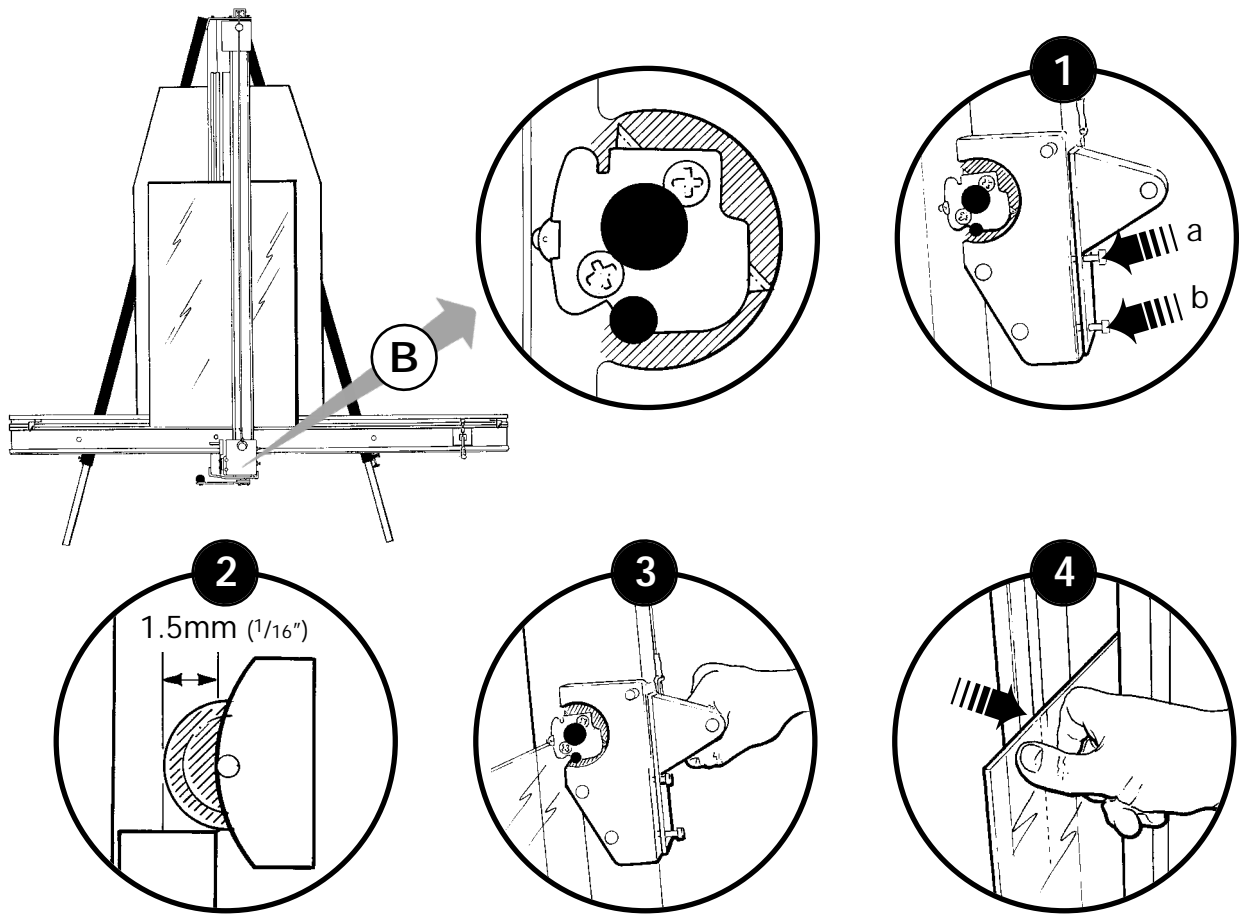

GB English

CUTTING GLASS – (Wear eye protection when cutting glass!)

- 1 Before attempting to cut glass it is wise to ensure that the pressure setting is correct for the thickness of glass to be cut. Adjustment is made by turning the spring adjustment screw (a) immediately below the handle. Clockwise increases the pressure and vice-versa.
- 2 The second adjustment screw (b) controls the height of the cutter from the surface of the material to be cut. The Glass cutter wheel should be set at approximately 1.5mm (1/16") below the surface of the glass. Turning the adjustment screw clockwise lift the cutters away from the surface and vice-versa.

Place the glass in the machine pressing it lightly back against the Blackboards.

- 3 Lower the Glass cutting wheel on the surface of the glass approx. 1/4" from the bottom edge and score a line to the bottom of the glass and then lift Glass cutting wheel onto the glass approx 1/8" (3mm) from the bottom edge and score a line upwards to the top of the glass.
- 4 To break the glass, apply firm pressure to both sides of the score line at either the top or the bottom edge of the glass.

NB: The spring pressure on the Glass cutter wheel should not produce a white line, but a fine score line which can be seen by placing a sheet of white paper behind the glass.

On large sheets of glass the break may only go part way down the score line, press again near the end of the break to continue it.

Never go over the score line twice.

We recommend the use of nipping pliers for the removal of amounts less than 15mm (0.625").

Do not apply additional thumb pressure to the Glass cutter whilst cutting - adjust the pressure correctly

Cutting Plexiglass, Acrylic

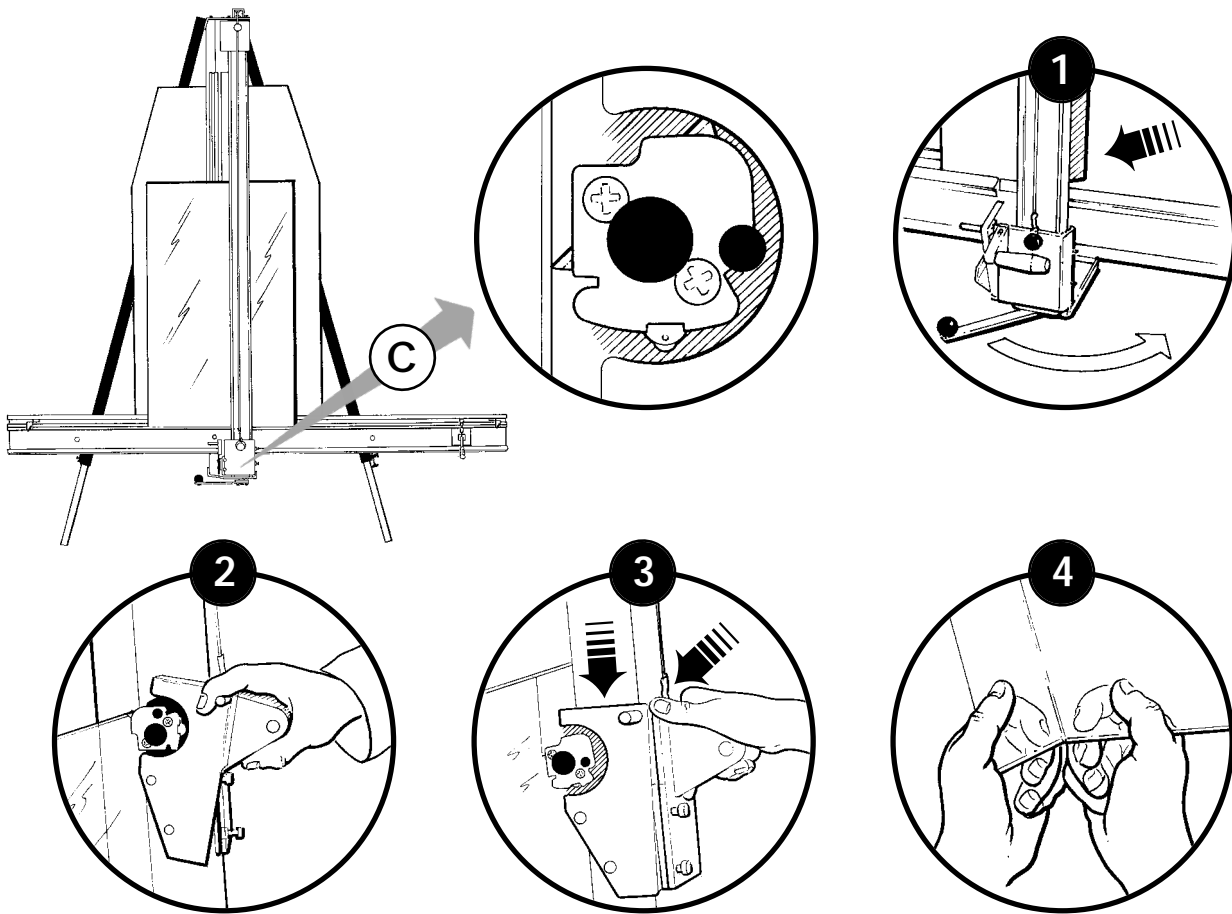

GB English

CUTTING PLEXIGLASS AND ACRYLIC SHEET

Select the plastic scoring blade tip © by rotating the turret. Check blade locking screw for tightness.

- 1 Set the measuring stops and clamp the plastic in place.
- 2 Lower the cutting tip on to the surface of the plastic.
- 3 Place the thumb of the right hand on the turret cover and apply moderate pressure to the blade tip. Score the plastic from top to bottom with one pass.
- 4 Remove the plastic from the machine and apply the pressure to the back of the score line at short intervals down the length of the cut to break.

SYSTEM 4000 / 3000

18 using your System

Cutting Hardboard/Masonite

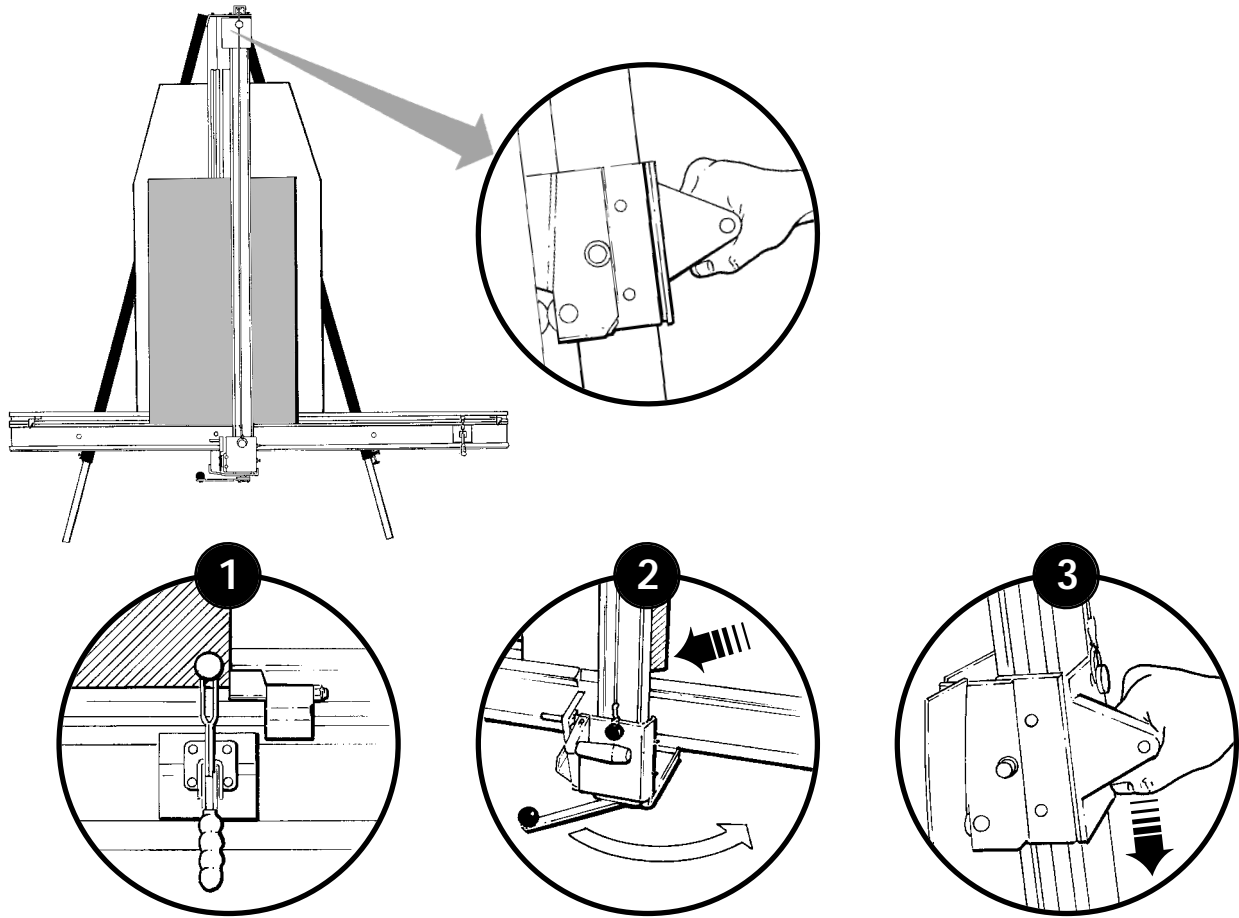

SYSTEM 4000 ONLY

GB English

CUTTING HARDBOARD/MASONITE

The Hardboard cutting head can be used for cutting Matboard and other card materials.

Ensure that the counterbalance is attached to the Hardboard cutting head. Set the measuring stops on the squaring arm to a desired setting and feed the hardboard under the slideway until it firmly contacts the measuring stop.

- 1 Lock the right hand corner of the board to be cut in place with the Toggle clamp.
- 2 Apply firm pressure with the long vertical clamp to stop the material bending during cutting.
- 3 Bring the Hardboard cutter down until it makes contact with the sheet edge and stop. Take a firm grip and then push the cutters down through the material without stopping.

You will need

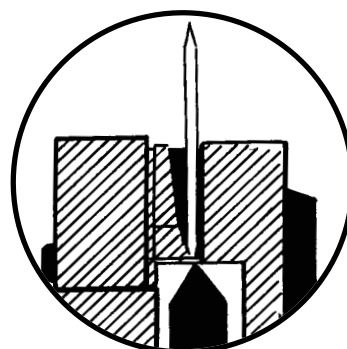
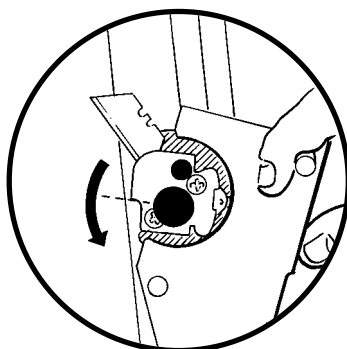
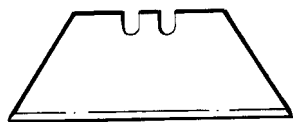
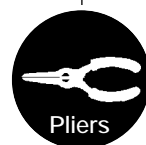

GB English

CHANGING THE UTILITY KNIFE BLADE

The Utility knife blade which is used for cutting cardboard, foamcore and the back edge for scoring plastic is changed by loosening the blade locking screw in the centre of the turret which has a black knurled head.

Remove the used blade and insert a new one behind the blade locking plate in line with the red arrow until it reaches its stop.

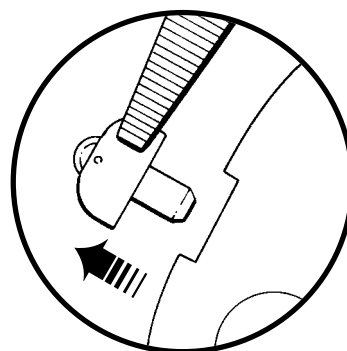
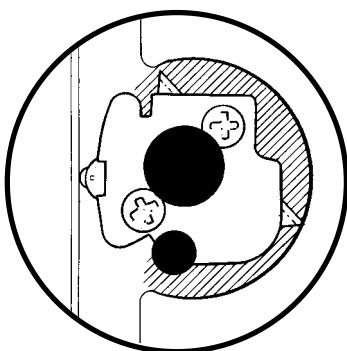
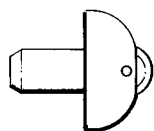

GB English

CHANGING THE GLASS CUTTING WHEEL

The Glass cutting wheel supplied with your machine is manufactured from high grade tungsten carbide material and if the correct pressure settings are maintained will give good service.

Using a small screw driver or thin pliers apply pressure to the underside of the wheel spindle. The Glass cutter will lift out of its location hole and slot.

Replace the new wheel and plastic holder taking care to press the holder back in to the slot to ensure that the wheel will stay straight in the machine.

SYSTEM 4000 / 3000

20 using your System

You will need



Changing the Hardboard cutting wheel carrier

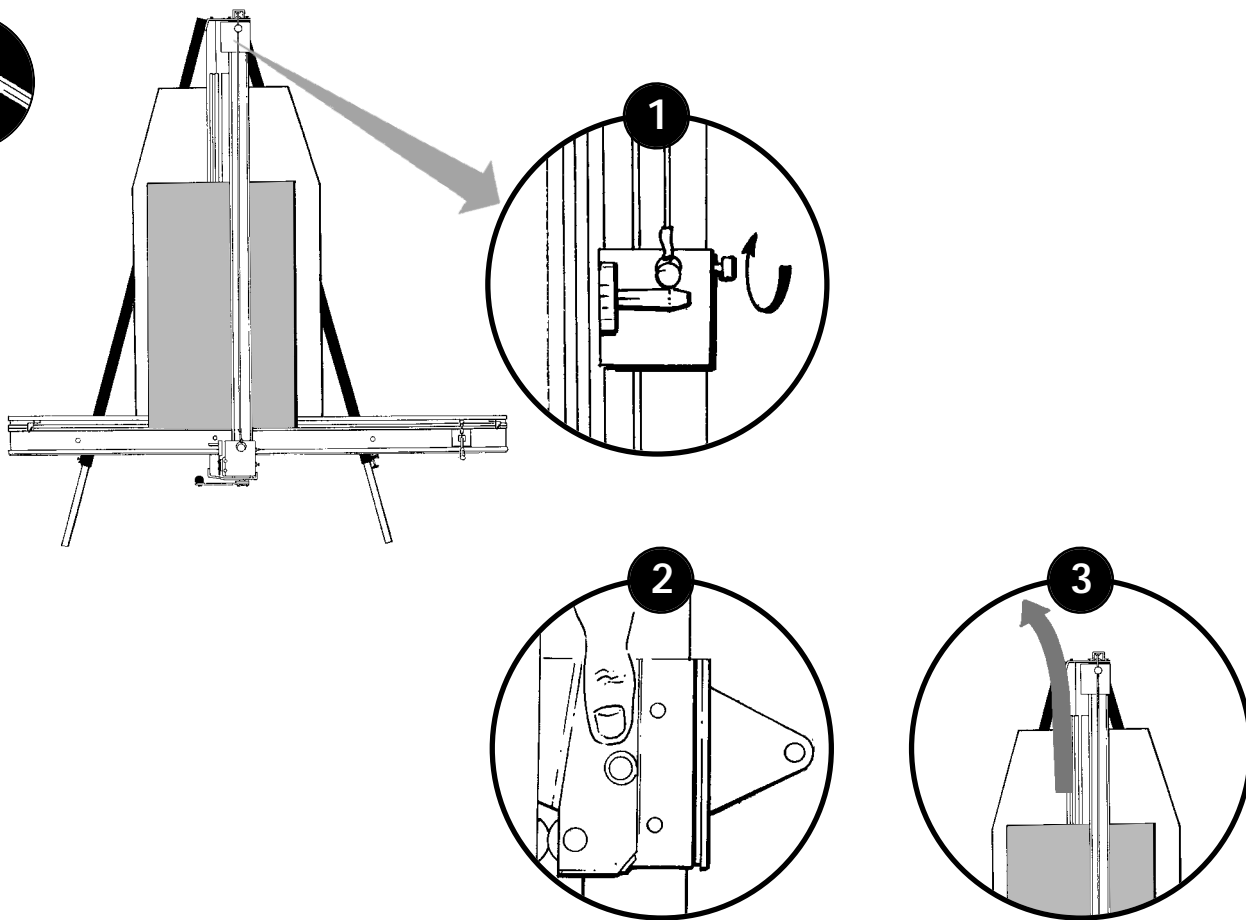

GB English

CHANGING THE HARDBOARD CUTTING WHEEL

- 1 Lock the Cutting head to the sideway using the white nylon locking screw at the convenient height.
- 2 Hold the wheel carrier and guard to prevent them from falling, and remove the allen screw.
- 3 Slide the wheel carrier towards the top of the machine and lift out.

SYSTEM 4000 ONLY

