

KEENCUT

GENERAL PURPOSE CUTTER

GB INSTRUCTION MANUAL

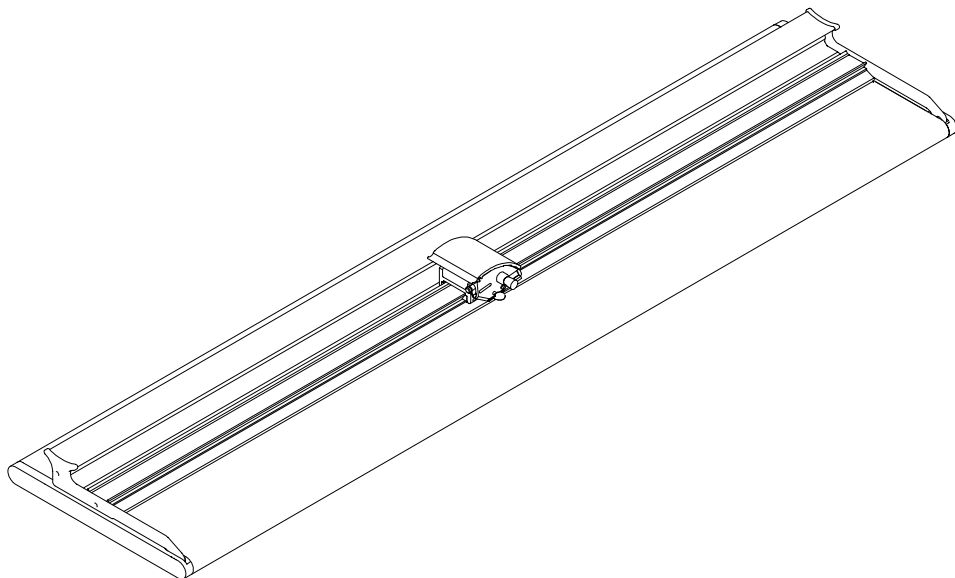

KEENCUT

THE WORLD'S FINEST CUTTING MACHINES

General Purpose Cutter User Instructions

Safety & Preparation

Thank you for choosing the General Purpose Cutter made by Keencut. Every effort has been made to bring you a superbly built product with the promise of many years of good service. In order to obtain maximum benefit from your machine please read these instructions carefully. For advice and assistance or replacement parts please contact your distributor or Keencut.

It is essential that the cutter is used on a flat surface to cut accurately. A warped or bowed table top can induce a twist in the Cutter Bar resulting in a bowed cut.

SAFETY

- The blade **must** be removed before moving, cleaning or lifting the Cutter.
- Only lift or move the Cutter using the Base Plate and keep upright when doing so.
- Do not place your fingers near the blade when using the machine.
- Do not use the Cutter if there are any signs of damage to the Cutting Head or Cutter Bar Assembly.



CUTTING DEPTH AND BLADE INFORMATION

The General Purpose Cutter has been designed to cut a variety of boards to a thickness of 10mm (0.4") using a Medium Duty utility blade.

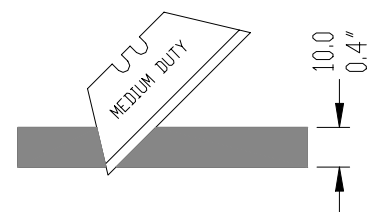

However, an increased cutting depth of 13mm (0.5") can be obtained using the KEENCUT XR utility blade, available from your distributor or Keencut.

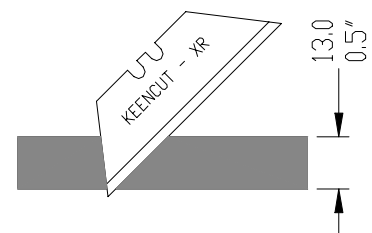

Consideration should be given to the toughness of the board being cut and the maximum depth of cut. It is recommended that heavy materials such as PVC foamboard should only be cut to a maximum of 6mm (0.25") whereas, lighter materials like foam centred board can be cut up to 13mm (0.5") thick using the KEENCUT XR blade

General Purpose Cutter User Instructions

Preparation & Use

INSERTING THE BLADE AND SETTING THE DEPTH

1. The blade is inserted from the back of the blade holder, push it fully forward and tighten the wingbolt.
2. To set the blade for a repeatable cutting depth unclamp the blade and turn the knob at the front of the cutter, clockwise to increase blade depth & counter clockwise to decrease. Re-clamp the blade before use.

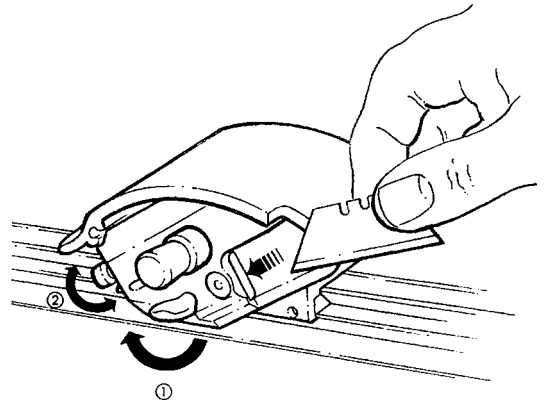

Set the blade depth so that you are only just cutting through the board, it takes much less effort and produces a better cut.

OPERATION

.....for cutting foam centred board, PVC foamboard and heavyweight materials.

Position the material under the cutter and align the sight edge with your cutting marks. The cutter will cut within 0.5 to 1mm [0.02" to 0.04"] of the sight edge, this small gap allows easier alignment when cutting to the edge of an image. Place your hand on the cutter, as shown, with the palm of your hand positioned over the groove on the front edge of the cutter. Place your left hand on the finger grip of the straight edge, depress the cutter and push it away from you to cut. Dependant upon the nature and thickness of the material you may need to take more than one cut gradually increasing the depth.

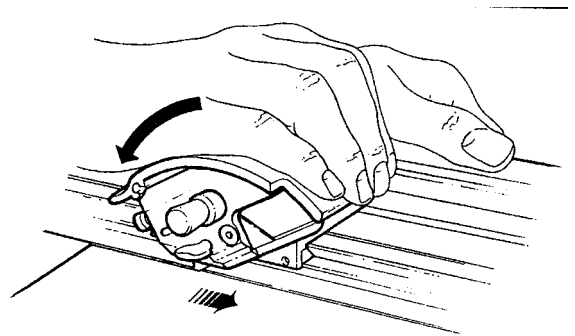

.....for cutting film and lightweight materials.

Position the material under the cutter and align the sight edge with your cutting marks. The cutter will cut within 0.5 to 1mm [0.02" to 0.04"] of the sight edge, this small gap allows easier alignment when cutting to the edge of an image. Place your hand on the cutter, as shown, with your finger tips positioned in the groove across the front edge of the cutter. Depress the cutter and pull to cut, there is no need to hold the cutter down when cutting

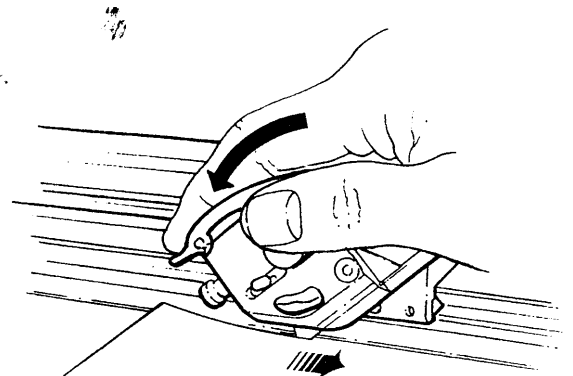

General Purpose Cutter User Instructions

Optional Fittings & Maintenance

THE ALUMINIUM SQUARING ARM (OPTIONAL)

Attach the Squaring Arm using the two screws and nuts provided. When tightening the screws ensure that the arm is at right angles to the cutting edge using a piece of paper or card cut at 90°, as shown.

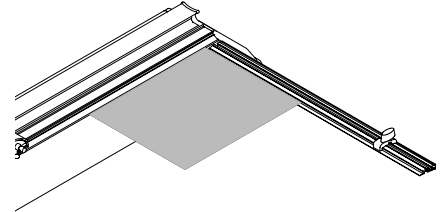
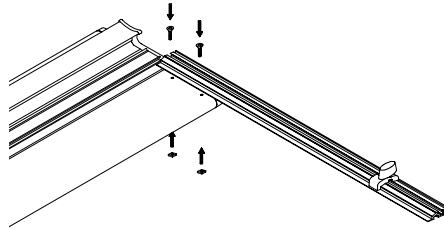

To fix the scales in the correct position, place a piece of card on the Squaring Arm and slide the measuring stop to the back corner then fasten it in position. Cut the card by depressing the blade and drawing it through the card smoothly. Measure the width of the card, and stick down the measuring scale so it reads the measured dimension at the stop.

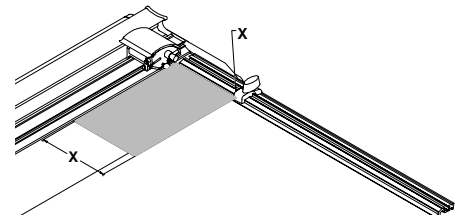

Do not use oil or spirits to lubricate or clean the cutter, some of the plastic components and bearings may be damaged.

CLEANING AND LUBRICATION

It is good practice to keep a dust sheet over the cutter if it is not to be used for extended periods. In any event regularly clean it with a dry cloth, to remove any stubborn stains use a cloth dampened with a little water/detergent.

Should the cutting head slideway require lubrication use a silicon spray or impregnated sponge.

CUTTING HEAD BEARINGS

The bearings that control the sliding motion of the cutting head are manufactured from a high grade polymer and under normal use will last for an extremely long time. As they settle into position you may find a slight amount of side play, this can be removed by tightening the two adjustment screws. Do not use oil or spirits to lubricate or clean the cutter, some of the plastic components and bearings may be damaged.

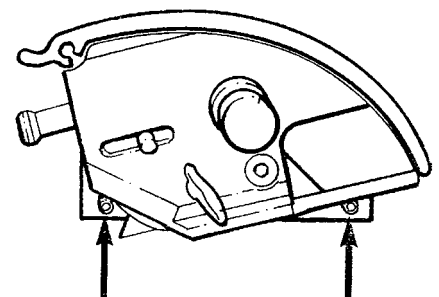

General Purpose Cutter User Instructions

Spare Parts

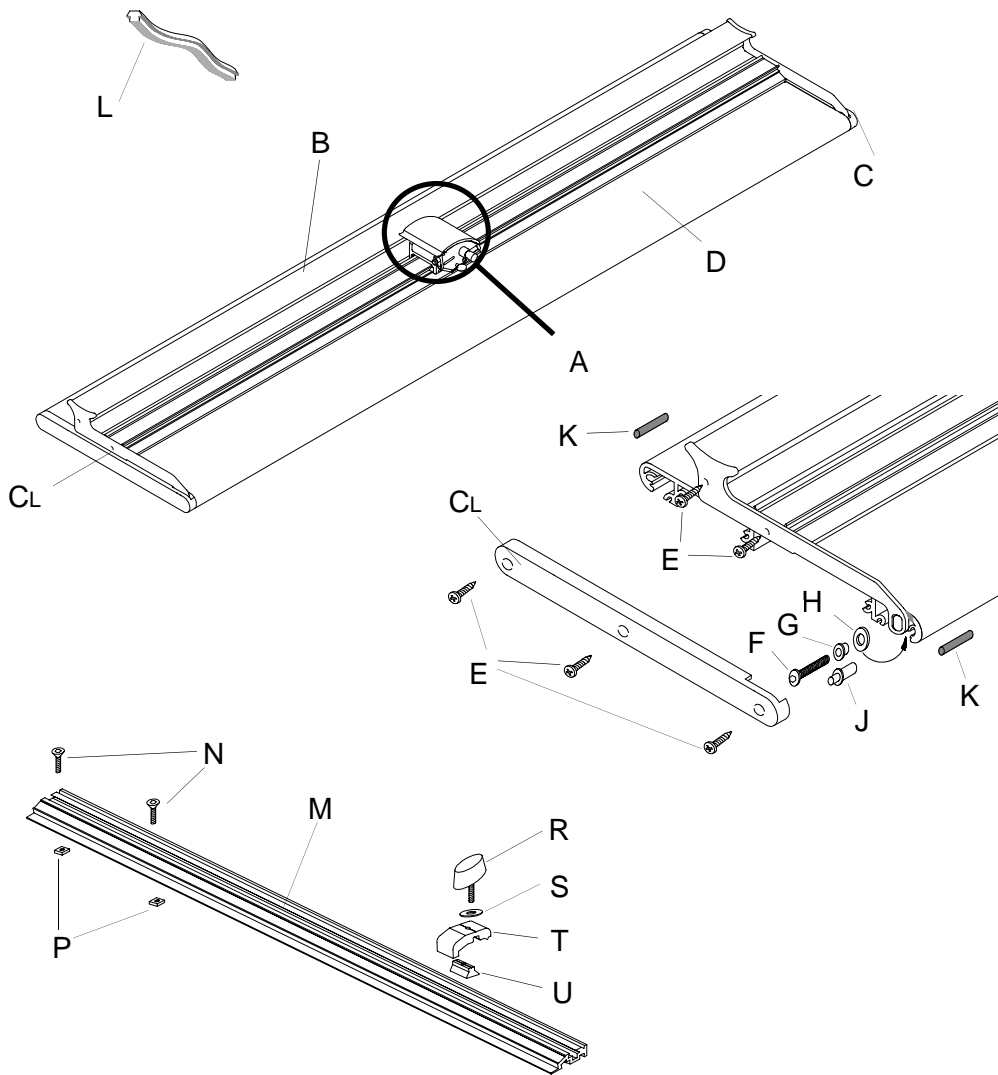

Key	Code	Key	Code
A	KS11/003	A1	KU01/071
B	KP0*/100	A2	CA30/023
CL	CA75/125	A3	CA25/052
CR	CA75/126	A4	CA10/250
D	KS11/10*	A5	KJ01/102
E	CA30/249	A6	CA30/122
F	CA30/167	A7	CA30/160
G	CA75/127	A8	CA25/164
H	CA30/277	A9	CA25/163
J	KS11/102	A10	KJ01/101
K	KS11/104	A11	CA30/137
L	CA75/113*	A12	CA30/214
M	KT05/107	A13	CA30/200
N	CA30/117	A14	KJ01/104
P	CA30/275	A15	KU11/141
R	CA30/007	A16	CA75/115
S	CA30/033	A17	CA30/247
T	KT05/108	A18	CA25/162
U	KL01/066	A19	KJ01/108
		A20	KJ01/103
		A21	KJ01/100
		A22	CA30/028
		A23	CA30/039
		A24	CA30/064
		A25	CA75/061
		A26	CA75/083

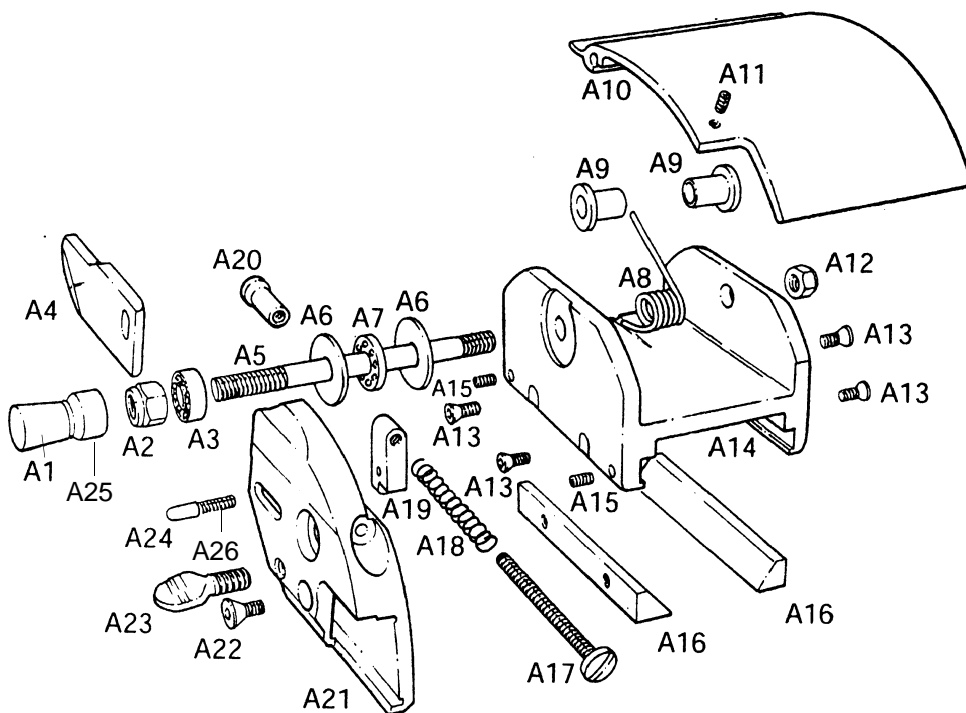

KEENCUT LIMITED
 Tel: +44 (0) 1536 263158
 Fax: +44 (0) 1536 204227
 Email: sales@keencut.co.uk
 Weldon South Ind. Estate,
 Corby, Northants England NN18 8AZ.

KEENCUT INC. (North American Sales)
 Toll Free: 1 800 240 5336
 Tel: 1 (519) 652 0970
 Fax: 1 (519) 652 0396
 Email: northamericansales@keencut.com
 #366 - 3560 Pine Grove Ave.
 Port Huron, MI 48060, USA