

**KEENCUT**

# ARTIST plus

GB INSTRUCTION MANUAL

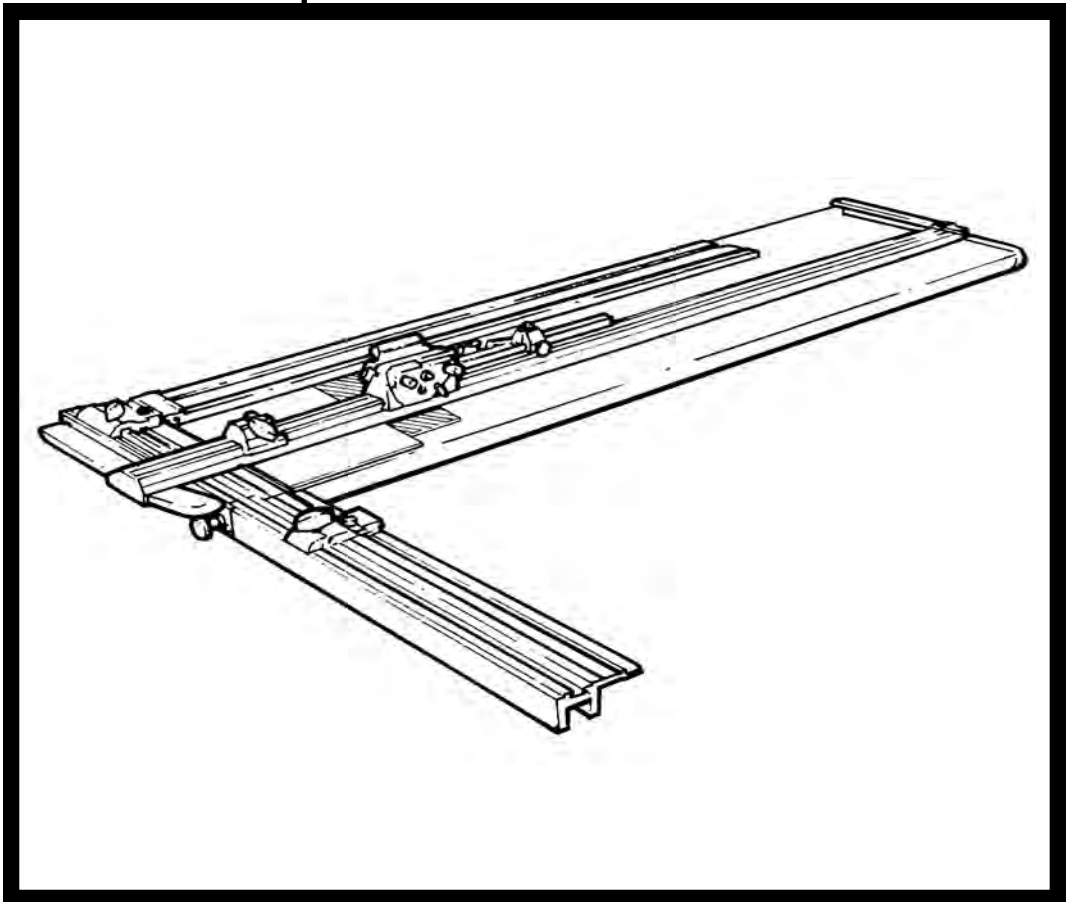

**KEENCUT**

THE WORLD'S FINEST CUTTING MACHINES

# User Instructions

## Contents

---

<b>3</b>	<b>Know your ARTIST plus</b>	
<b>4</b>	<b>Vertical Cutting</b>	(Cutting board to size)
<b>5</b>	<b>Bevel Cutting</b>	Preparation
<b>6</b>		Setting the Blade Depth
<b>7</b>		Setting the Limit Stops
<b>8</b>		Using the Limit Stops 1
<b>9</b>		Using the Limit Stops 2
<b>10</b>	<b>Maintenance</b>	Squaring 1
<b>11</b>		Squaring 2
<b>12</b>		General
<b>13</b>	<b>Cutting Techniques</b>	Unequal Margins
<b>14</b>		Offset Corner Mats
<b>15</b>		V-Grooves
<b>16</b>		Multiple Openings & Title Boxes

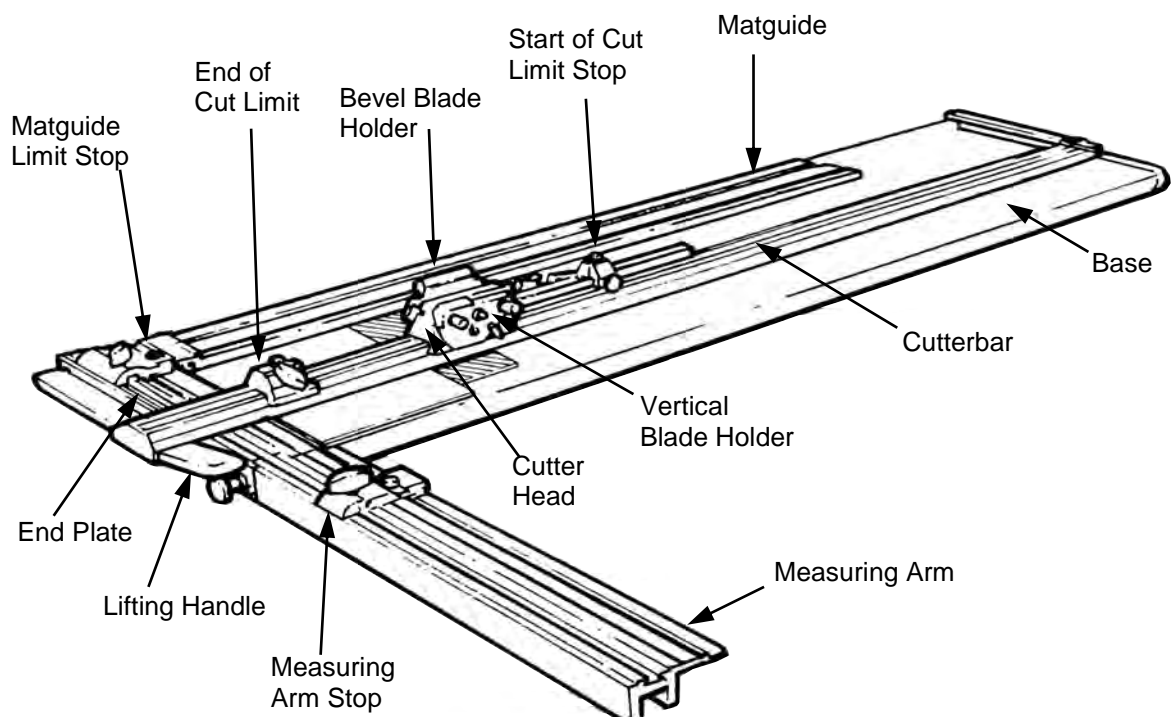

## User Instructions

### Vertical Cutting (Cutting Board to Size)

**VERTICAL CUTTING** is carried out using a standard trapezium shaped blade, these are thicker (0.017") and tend to distort less than the rectangular blades for vertical cutting.

Generally (clip frames excepted), providing the edge is straight, square and clean the quality of finish of the cut is less critical than with bevel cutting therefore the less expensive "Medium Duty Utility" blade can be used, for better results use "Keencut 080" blades.

**BLADE DEPTH** is important. The further the tip of the blade extends through the matboard the more difficult it is to cut.

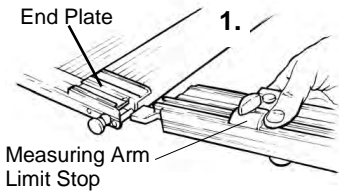
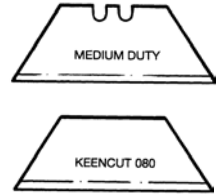

**THE MEASURING ARM** is used when cutting matboard to size (sizing) and can be removed when bevel cutting.

1. Present the Measuring Arm into the slot in the End Plate. Engage the Measuring Arm upwards into the slot and lower the Measuring Arm to horizontal.
2. Tighten the Measuring Arm locking screw.



**CUTTING BOARD TO SIZE** using the vertical cutter, fitted with a trapezium shaped blade adjust the depth so the tip of the blade **JUST** protrudes the board being cut. It is not necessary to use a slip mat when vertical cutting.

To enable the blade to be quickly set for the different thickness of materials such as paper, matboard and foamcore no preset stop is fitted.

Set the measuring Arm limit Stop to the dimension required.

Place the matboard under the cutter bar and position it so the bottom right corner is against the stop. Lower the cutter bar. Slide the cutter head away from you past the top edge of the matboard.

Depress the blade holder and pull the cutter head towards you.

**CHECK** that the matboard has been cut to the correct size. If the Measuring Arm has not given an accurate measurement then the Measuring Arm Limit Stop can be calibrated using the adjuster. Release the Adjuster Knob and slide the Adjuster to indicate the size of board just cut and retighten the Adjuster Knob.

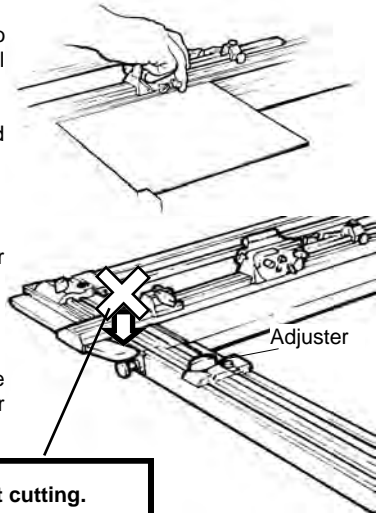

**Do not press on the handle whilst cutting.**

### Bevel Cutting - Preparation

**THE SLIPMAT** is used under the matboard when bevel cutting, this ensures crisp clean cutting.

Make it from standard matboard. Avoid using dense matboard such as black core.

Size - approximately 15cm (6") wide and either the full cutting length of the Artist plus long, or at least 5cm (2") longer than the longest mat you are going to cut.

When using - ensure the white side is uppermost and replace it when the surface damage becomes obvious.

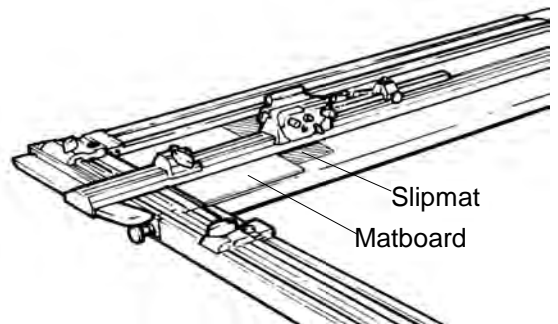

**BLADES ARE ONE OF THE MOST CRITICAL PARTS OF THE MACHINE**, in all cases the blade used should be the one most suited to the job in hand - when bevel cutting a precision ground and honed blade is required with an oil free surface (many blades are packed with an oil film to protect them) and the surface should be corrosion free.



The hardness and toughness of the blade is also critical.

All these factors add to the manufacturing cost of quality blades, however the option to use inexpensive blades leaves quality to chance and can increase wastage.

## User Instructions

### Bevel Cutting - Preparation

**BEVEL CUTTING** blades used on the Artist plus are rectangular and come in three varieties:-

	<b>TECH D 012</b>	Double ground edge 0.012" thick. (knife edge)	For general purpose cutting on most matboard (some are supplied with your machine)
	<b>TECH D 015</b>	Double ground edge 0.015" thick. (knife edge)	Both can give better results on some of the days thick and dense mat boards only trial and error can prove any benefit. If you require sample blades contact Keencut direct and a small quantity will be sent F.O.C We would be pleased to know your results!
	★ <b>TECH S 012</b>	Single ground edge 0.012" thick. (chisel edge)	

★ Please note: When using the Tech S.012 blades you can only use the one tip as indicated on the blade.

**BLADE DEPTH** is critical when bevel cutting. Too deep and hooking will occur, too shallow and the blade will not penetrate or meet at the corners. The tip of the blade should cut through the matboard and score the slip mat about 0.5 - 1 mm (1/64" - 1/32") deep. The method of adjustment is explained later.

**HOOKING** is when a curved cut is produced at the beginning of a bevel cut. This is caused by the blade bending or moving sideways when being pushed into the matboard, the blade then springs or moves back to its correct position as it begins to travel down the cut.

### Bevel Cutting - Setting the Blade Depth

The Artist plus has been tested and adjusted to give accurate results on a standard matboard. You may need to adjust the machine to give accurate cutting if your matboard is of a slightly different thickness to that of the test mat. Initially, do not worry about border width or over/under cuts we will explain that later.

★ **TIP** Change your blade regularly. The cost of half a blade (two cutting tips per blade) compared to matboard is negligible.

1.

Firstly, remove the blade left in the holder from test cutting slacken the clamping screw and slide the blade out from the back of the Bevel Blade Holder.

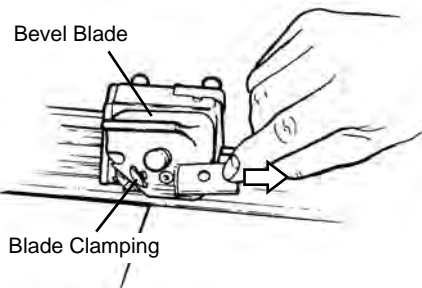

2.

Slide a new blade in from the back of the holder, push it forward against the blade stop.

Fasten the Blade Clamping Screw.

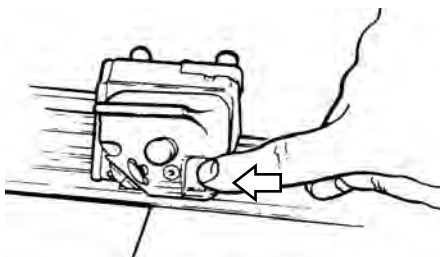

3.

Place the slip mat and matboard in the machine as for normal cutting. Slide the cutter head towards the edge of the matboard.

Depress the blade holder fully to penetrate into the slip mat at a point close to the edge of the matboard.

Inspect the amount of blade penetration into the slip mat, It should be 0.5 - 1mm (1/64" - 1/32").

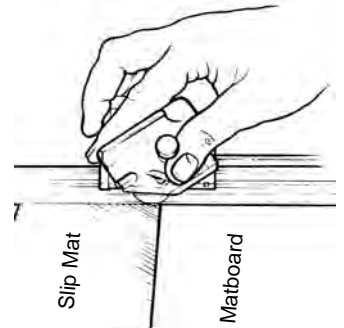

IF NOT

#### ADJUST THE BLADE DEPTH

Slacken the Blade Clamping Screw. Using the 2.5mm hexagon wrench, turn the Blade Depth Adjustment Screw clockwise to reduce the depth, counter-clockwise to increase it.

Press the blade forward against the blade stop, tighten the Blade Clamping Screw and check the blade depth.

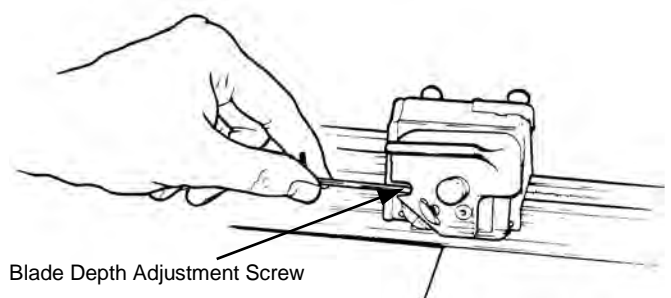

## User Instructions

### Bevel Cutting - Setting The Limit Stops

**THE LIMIT STOPS on the Artist plus are colour coded for ease of explanation. Do not alter the cursor settings at this stage, adjust the limit stops by means of the large black wing knob only, we will explain the cursor adjustment later.**

1.

Place your slip mat in position.

Lock the Matguide Limit Stop (blue pointer) on 3 (cms or inches) - this sets the border width.

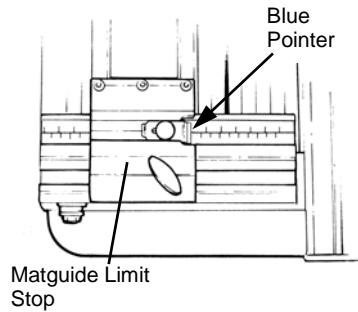

2.

Lock the Start of Cut Limit Stop (green pointer) on 3 (cms or inches) - this will position the blade in the correct place when you start cutting.

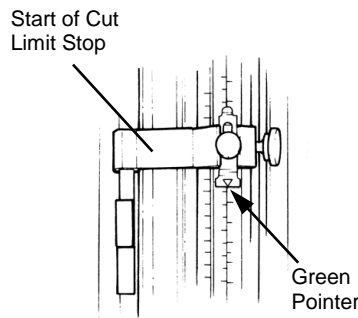

3.

Lock the End of Cut Limit Stop (red pointer) on 3 (cms or inches) - this stops the blade in the correct position

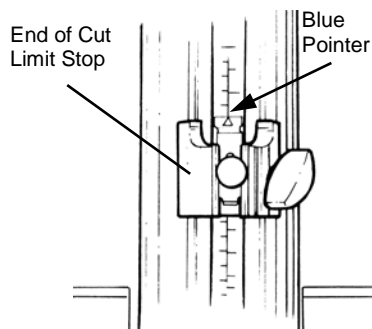

4.

Lift the cutter bar using the handle.

Place the matboard coloured face down on the slip mat. Ensure the two mat edges are aligned against the mat guide and end plate.

Lower the cutter bar to clamp the mat board and check the mat board contact with the mat guide and End Plate.

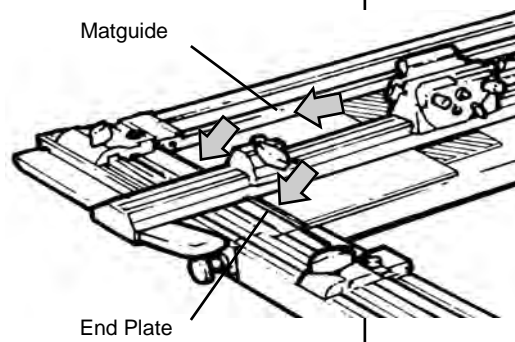

5.

Move the Cutter Head beyond the far edge of the mat board. Depress the Start or Cut Finger with the thumb of the left hand until it touches the surface of the slip mat.

Pull the cutter head towards you until the start of cut finger connects with the edge of the matboard and stops.

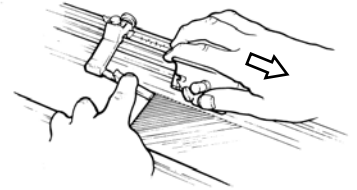

6.

Hold the start of cut finger down and fully insert the blade with firm downward pressure on the bevel blade holder.

Release the start of cut finger.

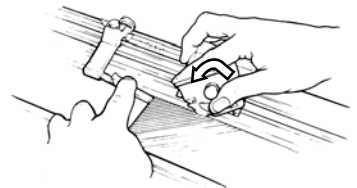

7.

Make the cut by pulling the Cutter Head until it stops against the End of Cut Limit Stop.

**Do not rest your hand on the handle whilst cutting as it will spoil the results.**

Release the Bevel Blade Holder.

Make three more cuts in the same way after turning the matboard counter-clockwise each time.

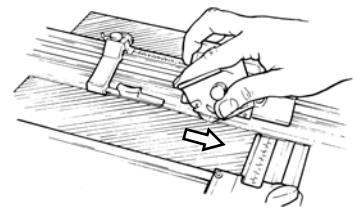

8.

To check if the cuts are accurate measure the border width on the coloured side of the mat board and look for over/under cuts in all corners. If there are inaccuracies the Limit Stops will need calibrating .

## User Instructions

### Bevel Cutting - Using The Limit Stops 2

The following instructions assume the border width of the mat is set at 3cm (3") as before.

Inspect the corners on the **coloured** side of the mat and decide if the overcut or undercut appears at the start or the end of the cut - remember the matboard has been turned over.

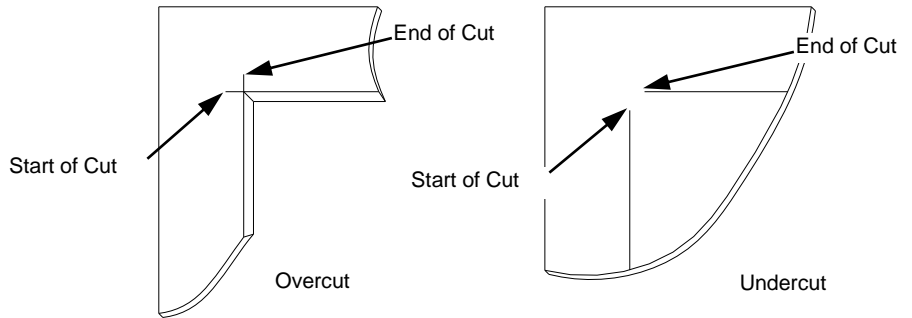

**START OF CUT** - Measure from the edge of the matboard to the beginning of the cut say it measures 3.1cm (3 1/16") giving an undercut, adjust the Start of Cut Adjuster (green pointer) so it reads what has been measured - 3.1cm (3 1/16") by releasing the Start of Cut Adjuster Screw and sliding the Adjuster.

Reset the Start of Cut Limit Stop to 3 in the normal way using the large knob, the Start of Cut is now calibrated for any size of mat made from that thickness of matboard.

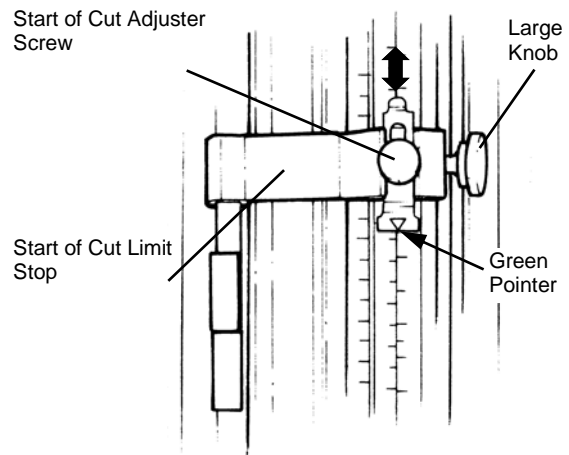

**END OF CUT** - Measure from the edge of the matboard to the end of the cut say it measures 2.9cm (2 15/16") giving an overcut, adjust the End of Cut Adjuster (red pointer) so it reads what has been measured - 2.9cm (2 15/16") by releasing the End of Cut Adjuster Screw and sliding the Adjuster.

Reset the End of Cut Limit Stop to 3 in the normal way using the wing bolt, the End of Cut is now calibrated for any size of mat made from that thickness of matboard.

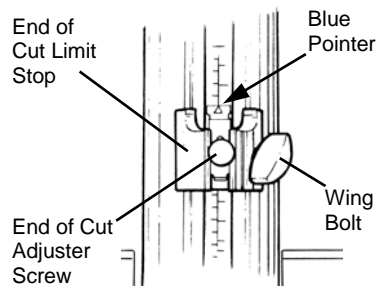

**All the stops have now been adjusted and set to cut an accurate mat for thickness of mat board you have selected.**

## User Instructions

### Maintenance - Squaring 1

**YOU SHOULD NOT NEED TO ADJUST THE SQUARING OF THE MACHINE!**  
**SQUARING THE CUTTER BAR AND MEASURING ARM** is carried out in our factory before despatch on all new machines. Therefore adjustment should never be necessary.

#### ALIGN THE MEASURING ARM WITH THE END PLATE

Attach the Measuring Arm (A) to the End Plate (B) and tighten the Locking Screw (C).

Lift the Cutter Bar and place a straight edge along the Endplate and the Measuring Arm, check they are in alignment. If not, loosen the two nuts (D) on the underside of the Measuring Arm, reposition the Arm with the End Plate and retighten the nuts.

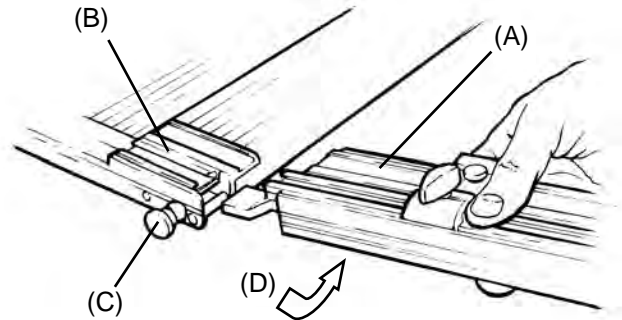

#### SETTING THE MEASURING ARM AND END PLATE SQUARE WITH THE CUTTER BAR

Take a matboard at least 65 x 65cm (25" x 25") in size. Clamp it under the Cutter Bar and trim off approx 1cm (1/2") from the left hand edge using the vertical blade, ensuring the bottom edge is in close contact with the Measuring Arm.

Turn the mat a quarter of a turn counter-clockwise and trim the same amount from the second edge.

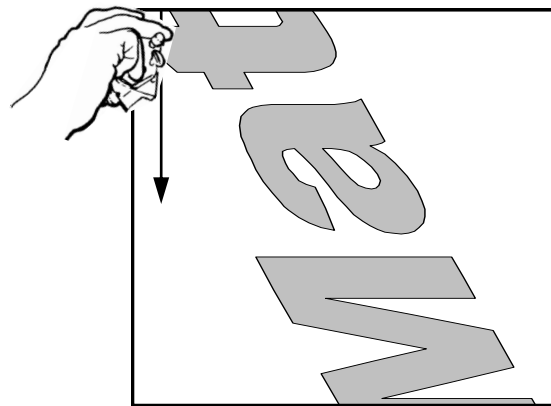
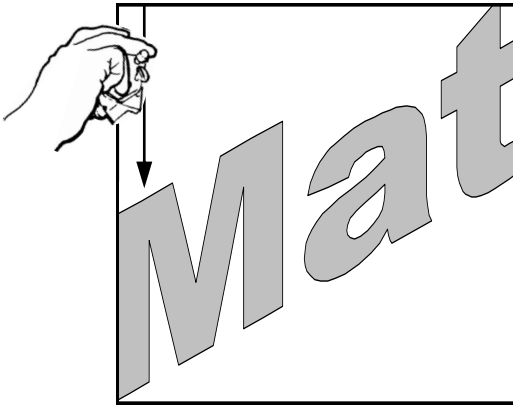

Repeat for the third edge.

And again for the fourth edge, always making sure the bottom edge of the mat is in close contact with the Measuring Arm

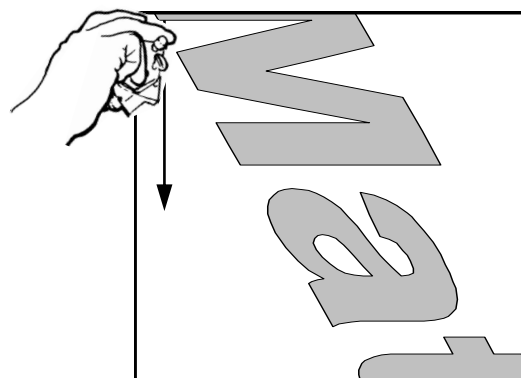
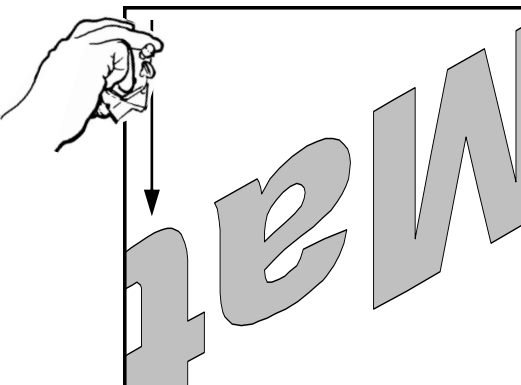

## User Instructions

### Maintenance - Squaring 2

#### CONTINUED

Rotate the mat a quarter of a turn counter-clockwise but this time place the bottom edge on the Measuring Arm/End Plate and slide it to the left until it comes into contact with the Cutter Bar.

**If the mat comes into close contact with the Cutter Bar along its whole length the machine is square**

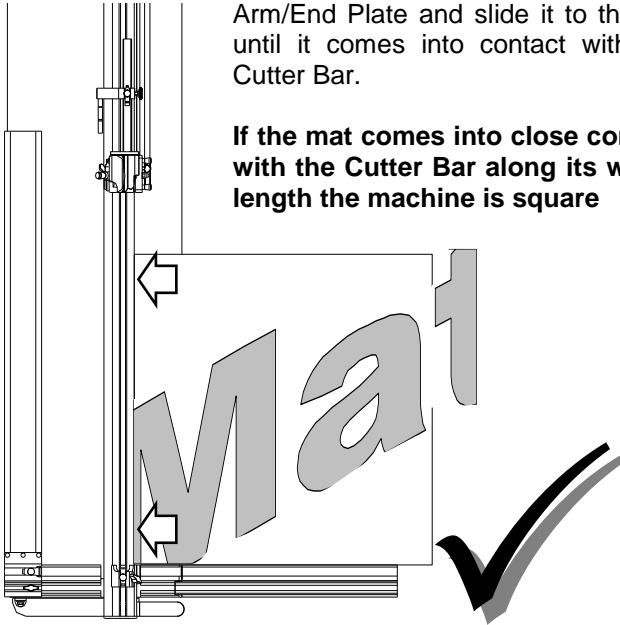

**IF THERE IS A GAP** between the matboard and the Cutter Bar, then the machine requires adjustment and this gap represents four times the error of the machine.

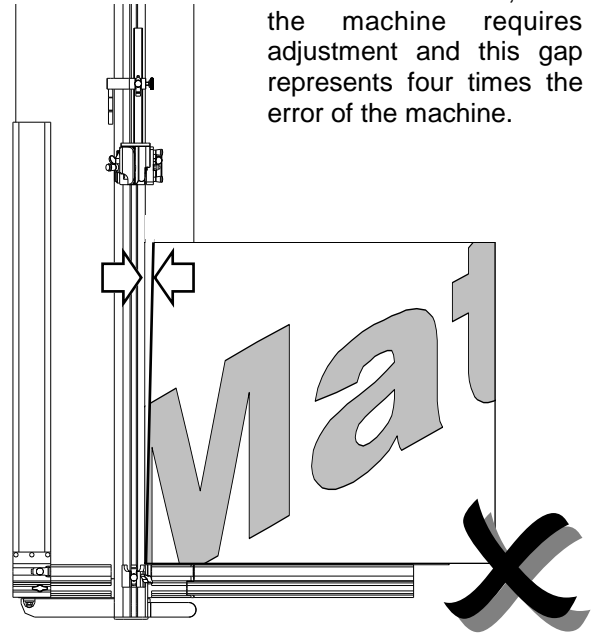

#### ADJUSTING THE END PLATE/MEASURING ARM

Loosen the three nuts (A) that hold the End Plate in position (they are on the underside of the base). Adjust the angle of the Measuring Arm and End Plate to close the gap by a quarter. Tighten the nuts and repeat the test, make further adjustments if necessary.

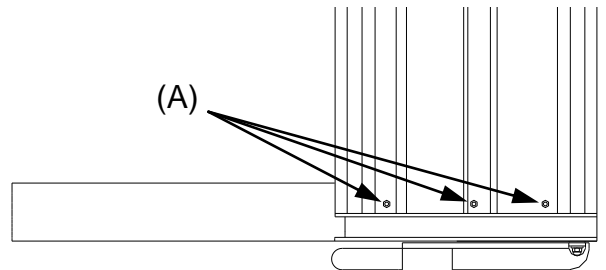

#### SQUARING THE MAT GUIDE

Place a strip of matboard under the Cutter Bar so that it does not protrude to the left of the Cutter Bar. Move the Matguide across to touch the Cutter Bar and tighten the Wing Bolt (W).

The Matguide should be parallel with the Cutter Bar and should touch long its whole length.

If not loosen the three Matguide Adjustment Screws (B) and the Wing Bolt, move the Matguide to the right until it touches the Cutter Bar along its whole length.

Tighten the Wing Bolt, then the Adjustment Screws whilst holding the Matguide onto the Cutter Bar.

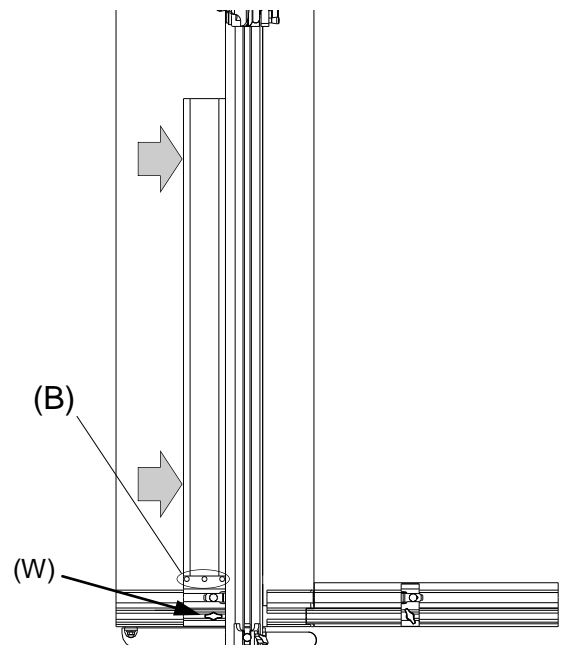



## User Instructions

### Maintenance

#### REMOVING THE START OF CUT RULE

Loosen screw (A) with 3mm hexagon wrench.

Set the vertical blade holder in the down position and loosen the second screw (B).

Remove the rule from the end of the cutter head.

If the machine is to be used without the start of cut rule for any reason adjust both screws inwards to ensure they do not interfere with the vertical blade holder.

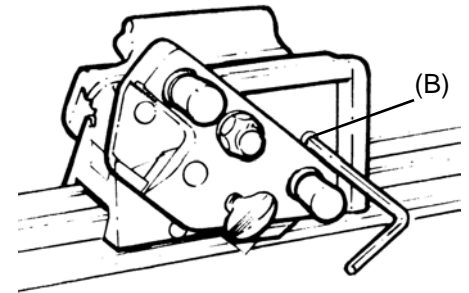
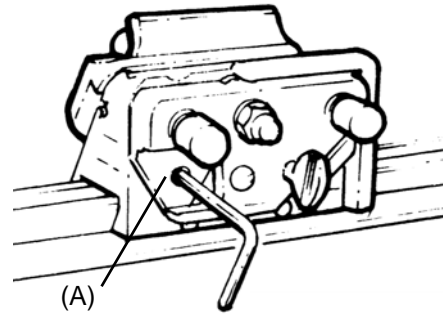

#### ADJUSTING THE CUTTER HEAD SLIDE BEARINGS

The bearings which control the sliding motion of the Artist plus cutting head are machined from a remarkable material called Ultra High Molecular Weight Polyfine and they will never wear out. As the bearings settle into position you may wish to adjust them to eliminate side play from the sliding head as follows:-

Remove the slip sheet to allow the cutter bar to lay flat on the machine base.

Place the 2mm hexagon wrench in the front bearing adjustment screw (A) and turn clockwise by small increments (1/16th of a turn) sliding the head each time to check for free running.

When the head slides less easily turn the adjustment screw back counter-clockwise by one small increment or two to restore free running.

Repeat steps 2 & 3 on the back bearing adjustment (B) first rotating the bevel blade holder to gain access to the head of the adjustment screw.

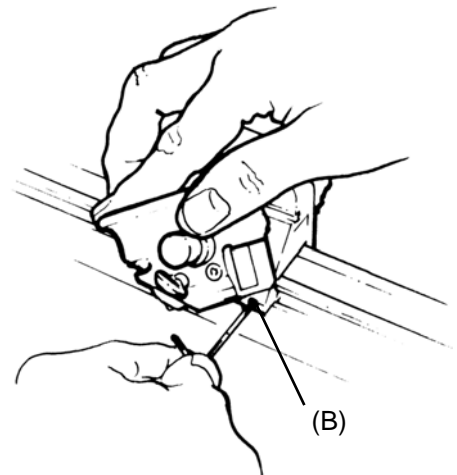
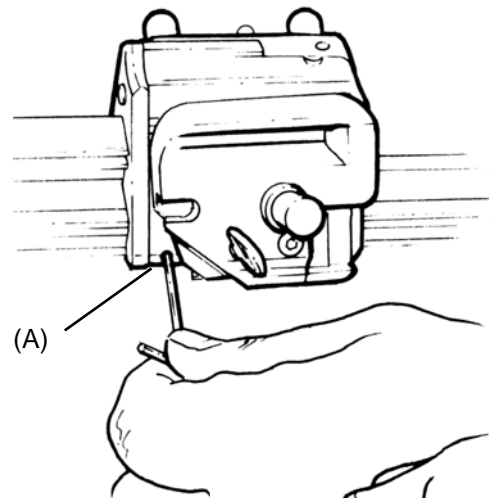

#### NOTE

It is not necessary to remove the head for cleaning and once the bearings are adjusted to your preference you may never have to do it again.

## User Instructions

### Cutting Techniques - Cutting Unequal Margins

**UNEQUAL MARGINS** - Cutting a mat with Unequal Margins, for example 3, 3, 3 & 4 (cms or inches)

Mark the back of the mat with margin widths on each of the four edges as shown.

Place the mat under the Cutter Bar, for the first cut:

Set the Matguide Limit Stop (blue) to the size shown on the left hand edge of the mat (to 3 in this case).

Set the Start of Cut Limit Stop (green) to the size shown on the top of the mat (to 3 in this case).

Set the End of Cut Limit Stop (red) to the size shown on the bottom of the mat (to 4 in this case), then make the cut.

Turn the mat 90 degrees counter-clockwise, set the red stop to 3 & make the second cut.

Again turn the mat 90 degrees counter-clockwise, set the green stop to 4 & make the third cut.

Lastly, turn the mat 90 degrees counter-clockwise, set the green stop to 3 & the blue stop to 4 make the last cut.

**NOTE:** Continue changing the Limit Stops before making each cut

	Set the Mat Guide to: (blue)	Set the Start of Cut to: (green)	Set the End of Cut to: (red)
1st cut	3	3	4
2nd cut	3	3	3
3rd cut	3	4	3
4th cut	4	3	3

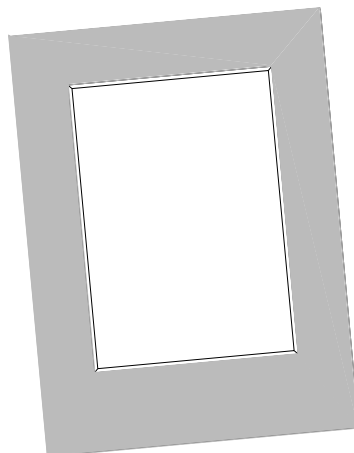
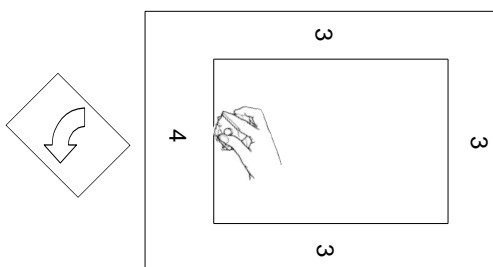
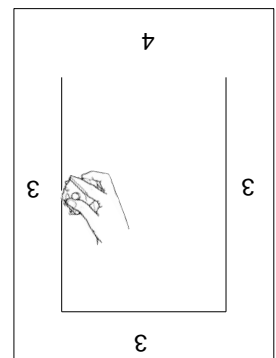
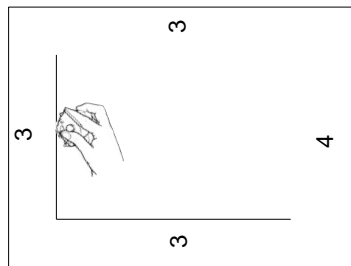
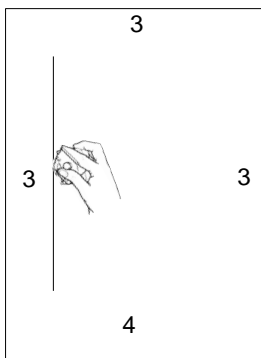

## User Instructions

### Cutting Techniques - Cutting Offset Corners Mats

**OFFSET CORNER MAT** - To cut an offset corner mat 2 sets of 4 cuts are made.

Only two dimensions are required (see drawing).

Set the Matguide Limit Stop (blue) to 3 (cms or inches).

Set the Start of Cut (green) and End of Cut (red) Limit Stops to 4.

Cut all four sides as for a normal mat.

Set the Matguide Limit Stop (blue) to 4 (cms or inches).

Set the Start of Cut (green) and End of Cut (red) Limit Stops to 3.

Cut all four sides but this time remove and then re-insert the blade at approximately the middle of all four cuts - the centre fallout will then be in one piece.

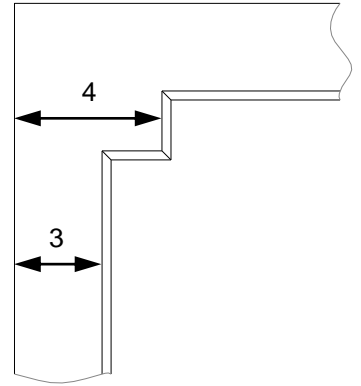

### DOUBLE OFFSET CORNER MAT

Set the Limit Stops to the dimensions in the table below. On the FIRST SEQUENCE and LAST SEQUENCE of cuts - remove and re-insert the blade at approximately the middle of all four cuts.

	Set the Mat Guide to: (blue)	Set the Start of Cut to: (green)	Set the End of Cut to: (red)	
1st set of cuts	3.5	3.5	3.5	- Lift Blade
2nd set of cuts	3.0	4.0	4.0	
3rd set of cuts	4.0	3.0	3.0	- Lift Blade

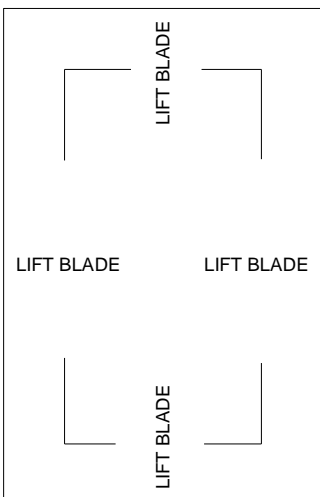
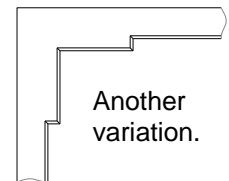
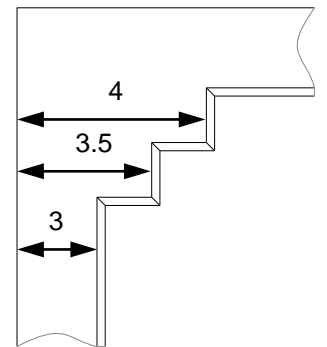

1st set of cuts

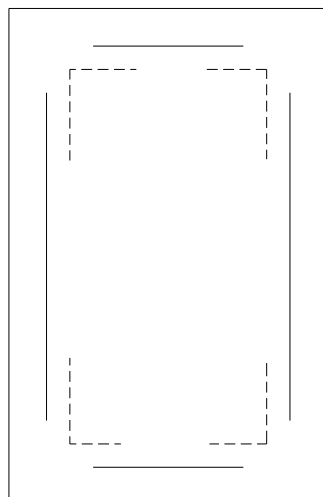

2nd set of cuts

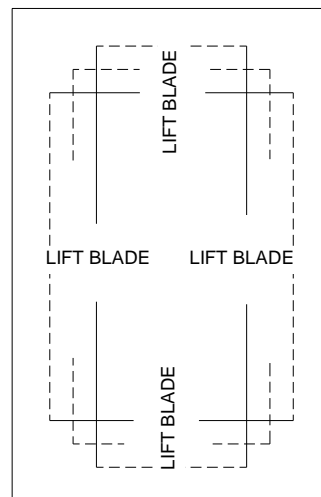

3rd set of cuts

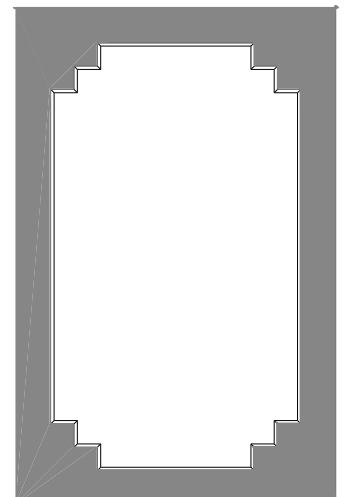

The finished Mat

## User Instructions

### Cutting Techniques - Cutting a V-groove

#### CUTTING A V-GROOVE

Lightly mark the back of the mat board with a pencil and then cut a mat.

Remove the mat and fallout and retain both.

Remove slip mat.

Set the Mat Guide forward so it is approximately 2mm (1/16") away from the Cutter Bar. This is only an initial setting and adjustment may be necessary after a trial cut, changing the width of the V-Groove is explained below.

Place the fallout (coloured face up) under the cutter bar against the Mat Guide.

Fully depress the blade and draw it through the card.

Take care to remove the trimming.

Repeat on the remaining three edges of the fallout.

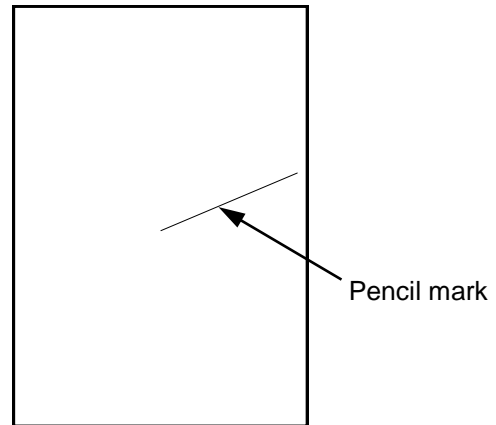

Place the fallout face down and position the mat on it using the light pencil mark as a guide to place the pieces back correctly.

Tape the mount and the fallout together along the cut lines.

**NOTE:** Use the thin tape or the thickness could upset the blade depth.

Take the assembled mat board and cut a mat inside the V-Groove in the normal way.

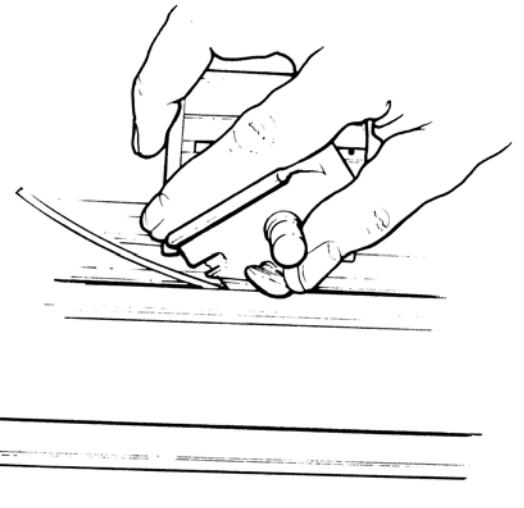

#### CHANGING THE V-GROOVE WIDTH

If the trial cut results in the V-Groove being too wide or narrow the gap set between the Margin Guide and Cutter Bar can be adjusted. Once a desired gap has been found a spacer can be made from board, plastic, wood, etc. so the setting can be returned to.

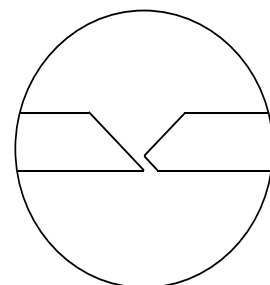

## User Instructions

### Cutting Techniques - Cutting Multiple Openings & Title Boxes

#### CUTTING MULTIPLE OPENINGS AND TITLE BOXES

The Start of Cut (green) Limit Stop can be used to great advantage after just a little practice to accurately cut multiple openings beyond the normal scope of the Stops.

Pencil mark the back of the mat board with the required layout and place an 'x' in each aperture to be cut. If the 'x' of the aperture to be cut is under or to the right of the Cutter Bar then the bevel will not be accidentally cut in the wrong direction.

Place the mat board under the Cutter Bar so the bevel blade cuts along the pencil line.

Set the Start of Cut (green) Limit Stop to zero.

Depress the Start of Cut Finger (A) and move the Cutter Head until the tip of the finger reaches the horizontal line at the beginning of the marked aperture.

Insert the bevel blade fully.

Release the Start of Cut Finger.

Cut until the engraved line on the Blade Support Plate (B) reaches the horizontal line at the end of the marked aperture.

Repeat until all the apertures are complete.

You may find small overcuts or undercuts in the corners, experiment with the Start of Cut setting (initially zero) and the finish position to the finish line on the Blade Support Plate to achieve a perfect corner.

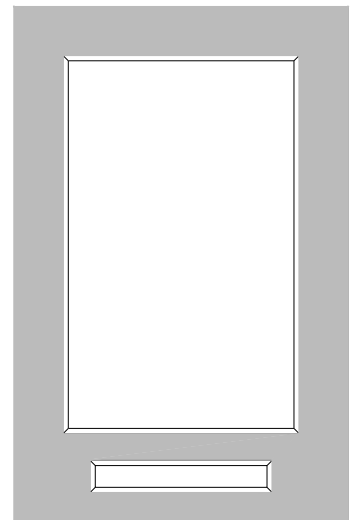
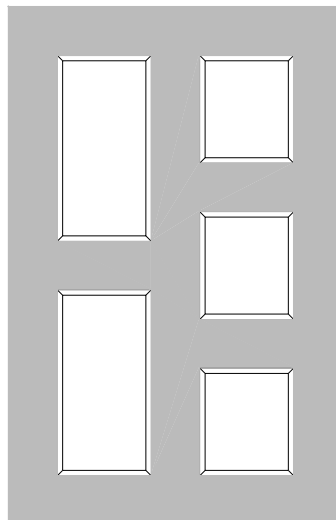
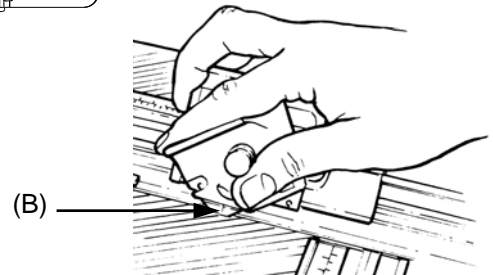
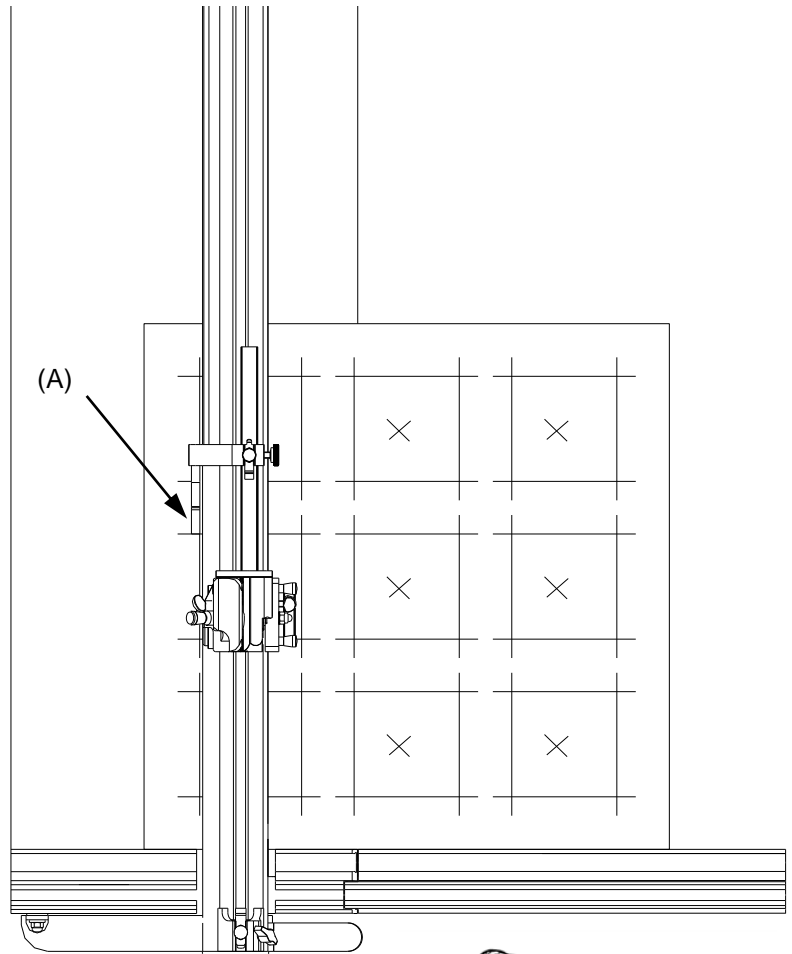

**KEENCUT LIMITED**

Baird Rd., Willowbrook Industrial Estate, Corby, Northants NN17 5ZA.

Tel: +44 (0) 1536 263158 Fax: +44 (0) 1536 204227

Email: [sales@keencut.co.uk](mailto:sales@keencut.co.uk)